

EXACT SCIENCES FROM JAINA SOURCES

VOL.-2

# Astronomy & Cosmology

RAJASTHAN

PRAKRIT BHARATI SANSTHAN

JAIPUR

SITARAM BHARTIA INSTITUTE OF SCIENTIFIC RESEARCH

NEW DELHI

**EXACT SCIENCES FROM JAINA SOURCES**

**Vol.-2**

# **ASTRONOMY AND COSMOLOGY**

by

**Prof. L. C. Jain**

Principal, Govt. P. G. College, Chhindwara

Foreword

**Dr. G. C. Patni**

Ex-Prof. and Head of Deptt. of Mathematics,  
University of Rajasthan, Jaipur



Publishers

**RAJASTHAN PRAKRIT BHARTI SANSTHAN, JAIPUR;  
SITARAM BHARTIA INSTITUTE OF SCIENTIFIC RESEARCH,  
NEW DELHI**

*Publishers :*

**DEVENDRA RAJ MEHTA**

Secretary

Rajasthan Prakrit Bharti Sansthan

Yati Shyamlalji Ka Upashray

3826, Moti Singh Bhomiyon-Ka-Rasta,  
Jaipur-302003.

**O. P. BHARTIA**

Sitaram Bhartia Institute of Scientific Research

27-Bara Khamba Road,

New Delhi-110001



© Rajasthan Prakrit Bharti Sansthan



First edition, 1983



*Price :* Rs. 15.00



*Printed by :*

Friends Printers and Stationers

Johari Bazar,

Jaipur.

## **PUBLISHER'S NOTE**

Rajasthan Prakrit Bharti Sansthan, Jaipur, has many streams of publications; it brings out books on philosophies, religions their comparative studies, history, art & culture, ancient literary works, Prakrit language and secular scientific subjects etc. On the last one presently we propose to bring out a series of ten books in collaboration with Sitaram Bhartia Institute of Scientific Research, New Delhi, out of which this is the second one.

We are indeed grateful to Professor L. C. Jain, an eminent authority on history of mathematics, to have written this book which might be useful in appreciating the contribution of ancient scholars to the development of mathematics.

We are also indebted to Dr. G. C. Patni formerly Professor and Head of Department of Mathematics and Dean, Faculty of Science, University of Rajasthan, Jaipur for contributing the foreword of the book.

Mahopadhyaya Shri Vinay Sagarji Sahab, Joint Secretary of our Society arranged its publication through Friends Printers & Stationers, Jaipur. We are grateful to both of them.

**O. P. BHARTIA**

Sitaram Bhartia Institute of  
Scientific Research  
NEW DELHI

**D. R. MEHTA**

Secretary,  
Rajasthan Prakrit Bharti Sansthan,  
JAIPUR

**ERRATA (VOLUME-II)**

<b>PAGE</b>	<b>LINE</b>	<b>FOR</b>	<b>READ</b>
1	16 (from top)	against	above
2	5 (from bottom)	Newyork	New York
3	15 (from top)	c	c.
9	2 (from bottom)	ē	e
23	7 (from top)	speculating	speculating
26	14 (from top)	anubhāg	anubhāga
	4 (from bottom)	k	K
	12 (from bottom)	k	K
	16 (from bottom)	k	K
29	7 (from top)	EQUINOXE	EQUINOXES
	8 (from top)	Jyo <sup>16</sup> tiṣa	Jyotiṣa <sup>16</sup>
31	10 (from top)	fiṣt	fiṣt
43	19 (from top)	NAKSATRAS	NAKṢATRAS
48	7 (from bottom)	nakṣatres	nakṣatras
51	9 (from bottom)	comperative	comparative
54	3 (from bottom)	Ārybhaṭa	Āryabhaṭa
61	6 (from top)	Chakraverty	Cakravarti
63	5 (from bottom)	Ārybhaṭa	Āryabhaṭa
	18 (from bottom)	Cirumference	Circumference

# CONTENTS

TOPICS	PAGES
0. Foreword	1-12
1. Introduction	1-7
a ) Science Awakening	2
b ) Jaina Cosmos	5
2. Technical Terms	8-11
a ) Celestial Diagram	8
b ) Index of the Diagram	10
3. Source Material	12-15
a ) Vedic Literature	12
b ) Vedāṅga Jyotiṣa	13
c ) Jaina Tradition	13
d ) Literature in Śvetāmbara School	14
e ) Literature in Digambara School	15
f ) Certain Contributors	15
4. Cosmological Concepts	16-28
a ) Evaluation of Rajju	16
b ) Volume of Universe	17
c ) Another Value of Rajju	18
d ) Frame of Descartes	19
e ) Cosmic Periods and Cycles	21
f ) Yuga Bhagaṇa	22
g ) Concepts of Palya and Sāgara	23
h ) Concept of Kalpa	24
i ) Parāvartana Periods	25
j ) Comparability	27
5. Astronomical Concepts	29-37
a ) Precession of Equinoxes	29
b ) Date of Adoption of Calendar	31

c ) Pañcāṅga	32
d ) Graduation of Celestial Sphere	33
e ) Note	37
<b>6. Kinematics of Astral Bodies</b>	<b>38-49</b>
a ) Nakṣatra System Abroad	38
b ) Mathematical Astronomy	39
c ) Symmetric Setting	40
d ) Shadow Planets	41
e ) Motion of Astral Bodies	42
f ) Relative Motion of Nakṣtras	43
g ) Relative Motion of the Sun	45
h ) Relative Motion of the Moon	47
<b>7. Rationalization of Yojana</b>	<b>50-53</b>
a ) Chinese Li	50
b ) Types of Aṅgulas	51
c ) Evolution of Yojana	51
d ) Rationalization	52
e ) Height as Latitude	53
<b>8. Calendrical Yuga System</b>	<b>54</b>
<b>9. Astronomical Theory</b>	<b>55-60</b>
a ) Principle Theories	57
b ) Constructive Theories	57
c ) What is Jaina Theory ?	58
d ) Eclipse Theory	58
e ) Evolution of Epicycles	59
<b>A. Bibliography of Source Material</b>	<b>61-62</b>
<b>B. Bibliography of Some Research Material</b>	<b>63-66</b>
<b>C. Bibliography of Books</b>	<b>67-69</b>
<b>D. Abbreviations</b>	<b>70</b>
APPENDIX-A	71
APPENDIX-B	72

## FOREWORD

Cosmology and Astronomy are some of those topics of 'Exact Sciences' towards the development of which the Jaina School of Pārśvanātha and Vardhamāna Mahāvira has contributed a lot. This School, noted for its mathematicophilosophic pursuits, flourished in India very much close round about the same period in which the School of Pythagoras flourished in Greece, that is, in sixth century B. C. and later on. The vast available ancient Jaina literature is primarily religion-cum-philosophy oriented, but the use of mathematics is found in abundance, showing that the Jains at that time had developed mathematics to a great extent. The ancient Jaina literature is divided into four main groups, called prathmānūyoga, karaṇānūyoga, caraṇānūyoga and dravyānūyoga where looking to the importance of science, most of the literature of the karaṇānūyoga group deals with mathematical, astronomical and cosmological concepts besides the study of cosmos and self and the Karma Theory. As a matter of fact for this study, two worlds, one the macroworld and the other microworld, are to be well manifested to a human intellect and with this object, in view, the Jaina scholars in ancient India have worked on Astronomy, Cosmology and the Karma Theory with mathematical approach.

The original Jaina Āgamas discuss, amongst other things, the Karma Theory. In these lie the deep secrets of periodic events of nature. It is unfortunate that many of these Āgamas in which mathematics has been developed either as post-universal (alaukika) study of measures and counting or applied in the form of results through analysis and comparability, e. g., the works of Bhadrabāhu of 3rd-4th century B. C. either have been lost or are not traceable at present. Some of the important available Āgamas and other texts, their extracts and commentaries are the Kasāya-pāhuḍa, the Ṣaṭkhaṇḍāgama, the Sthānāṅga-Sūtra, the Tattvārtha-Sūtra, the Tiloyapaṇṇatti Kṣapaṇāsāra, Labdhisāra, the Gommaṭasāra, the Trilokasāra, the Dhavalā, the Jayadhavalā, the Mahādhavalā, the Jambūdvapaṇṇatti Saṃgaho, the Gaṇitasāra Saṃgraha, the Sūryaprajñapti, the Candraprajñapti, the Lokavibhāga etc. Some of these works are more than 2000 years old and many of them lay hidden and could be brought to light only recently through the

efforts of some Indian and foreign scholars. The names of M. Raṅgācārya (c. 1912 A. D.), D. E. Smith, S. K. Das, H. L. Jain, A. N. Upādhyāya, Kāpaḍiyā, A. N. Singh, B. B. Datta, N. C. Jain, T. A. Saraswati, L. C. Jain (the present author), R. C. Gupta, Lishk and Sharma, J.C. Sikḍar, Voloḍarṣki etc. are worth mentioning as main workers in the field of Jaina Mathematics.

In Sthānāṅga-Sūtra, the Jain canonical work of about 300 B. C., rāśi forms one of the ten topics for discussion. Here rāśi is synonymical with samūha, ogha, puñja, that is, a set, though the rāśi appears in other Jaina texts in several contexts also; cosmological sets are found in detail in Tiloyapaṇṇatti, a work of Yati-Vṛṣabha of 5th century A. D. Philosophical sets relating souls, their becomings, nature of Karma, the number of particles involved therein, alongwith their intensity of reactions and stay periods, the deep-rooted theory of 'bhāva' becoming operators etc. may be found in great details in the other important Jaina source work, 'Ṣaṭkhaṇḍāgama', compiled and composed by Puṣpadanta and Bhūtabali during the first two centuries of the Christian era and the commentaries on this work by Virasenācārya given in early part of the 9th century A. D. under the name 'Dhavalā' which contains a lot of valuable information about Mathematics. Trilokasāra, summary of the three universes as the name indicates, has been compiled by Nemicandrācārya of 11th century A. D. from earlier Prakrit texts, one of them being the Tiloyapaṇṇatti mentioned above; this work and its commentaries by Mādhavacandra Traividya (c. 1203 A. D.) and translated into a ḍhūṇḍhāri work 'Artha Saṃdṛṣṭi' by Toḍaramaḷa (c. 1720-1768 A. D.) also describe various other mathematical topics and concepts, for example, the fourteen types of sequences for elaborating the number-measure (Saṃkhyā-māna) and the simile-measure (Upamā-māna).

In the literature of karaṇānuyoga group, detailed description of the universe is given and related to this, the description of the sun, the moon, the nakṣatras, the oceans, the islands, etc. using a lot of mathematics has been provided. All these works are very useful in following the development of ancient Indian Mathematics and Astronomy. In Vedic tradition, the subject of Mathematics has been dealt with cursorily in texts like Vedāṅga Jyotiṣa. However Āryabhaṭa First of 5th century A. D. was perhaps the first Indian mathematician-astronomer who in his book, 'Āryaṣṭaśta (Ārya-Bhaṭṭiyam), has added a separate independent chapter consisting of 33 verses on Mathematics and Astronomy. He was also the first astronomer who had pointed out that the sun and the stars were fixed and also calculated the circumference of the earth and gave scientific reasoning for the occurrence of the solar and lunar eclipses. Another Indian Mathematician, Brahma-

gupta of 7th century A. D. also added one separate chapter on mathematics in his book, *Brahmasphuṭa Siddhānta*. But it was the Jaina scholar-saint Mahāvīrācārya (c. 850 A. D.) who for the first time had written a separate book, 'Gaṇitśāra Saṃgraha', entirely on mathematics. Even the Bakhṣālī manuscript found in Bakhṣālī village near Peshawar in 1881 is said to belong to 12th century A. D., though according to some scholars, it may belong to 3rd or 4th century A. D. also. However, much long before Āryabhaṭa I, mathematics, astronomy and cosmology alongwith other subjects of science, arts, humanities and social sciences, had been developed in India—a fact which has been acknowledged now even by western scholars. Various astronomical phenomena whether they be related to the sun, the moon, the other heavenly bodies, the constellations, the eclipses, the conjunction of planets, tripraśna (direction, position and time), the measurements of small or extensive dimensions of lengths and heights of small or big bodies like the paramāñūs, the cities, the oceans, the islands, the mountains, interspace distances between the different worlds—universe and sub-universes—the hellish universe, the human universe, the sub-human universe, the gods' universe (heavens) and also subjects like the configuration of living beings, the lengths of their lives, their progress, their staying together, that is, in other words whatever there is in all the three worlds (triloka) which consist of moving and non-moving beings (the six fluents) and which cannot exist apart from gaṇita, have been described in the ancient Jaina Prakrit texts.

As mentioned in the book, 'Science Awakening' by B. L. Vander Waerden, the use of the sexagesimal system in Astronomy is 5000 years old. The Babylonians needed knowledge of calendar in connection with agricultural problems and for this they had taken the beginning of their year, with effect from the vernal equinox. These Babylonians had adopted this system from Sumerians and from the Babylonians. The Greek scholar-astronomer Ptolemy (c. 150 A. D.) had adopted it in Greece. Further Neugebauer has opined in 'The exact Sciences in Antiquity' that the decimal place value notation is a modification of the sexagesimal system with which the Hindus became familiar through Hellenistic astronomy. Whether it is correct, is doubtful since the period of 300 B. C. to 300 A. D. is the Hellenism Yuga; during this period Greek science and astrology was developed in Alexandria (Greece) while arithmetic and astronomy remained static. For the period before 300 B. C., even Herodotus, the pioneer of ancient Greek history, is generally silent.

As mentioned in Encyclopedia Americana, the two Greek Scholars Thales (640 B. C.) and Pythagoras (6th century B. C.) both travelled to Egypt in Saitic period (663–525 B. C.) and Pythagoras is believed to have

travelled to Babylon and other countries as far as India also. The astronomy in Egypt however could not develop in comparison with the Babylonian and Greek astronomy but it is now an admitted fact that the Hindus had developed their mathematics and astronomy many centuries before Christ and as mentioned above, the ancient Jaina School of Mahāvira flourished very much in India round about the same period in which the Pythagorean School flourished in Greece.

According to vander Waerden in his book, 'Science Awakening', "Herodotus has reported that Thales had predicted the event of solar eclipse of 585 B. C. It is believed that Thales was the first Greek astronomer to predict a solar eclipse. Such a feat required the experience of more than forty years, no matter how one proceeds. It is not possible for one man alone to gather this experience. But Thales had no Greek predecessors. The conclusion is inescapable that he must have drawn upon the experience of Oriental astronomers." These Oriental astronomers might be Babylonians and Hindus only. It is possible that Pythagoras might have been influenced by the Jaina thinking of his time which is evident from the fact that he took the number 59 as the basis of his lunar calculations. In Prakrit Jaina texts, the number 59 has been taken as the basis of all lunar calculations since the days and nights in every one of the moon's months total to 59; it is because of the fact that in relation to the sun, the moon lags behind 62 celestial parts in one muhūrta and therefore takes  $59\frac{1}{3}$  days to cover 109800 celestial parts. It is important to note here that the ayan system of the Hindus is different from that of the Jains and does not consider 59 days as above.

Taking into account the various factors, we can say that one of the important links, in the sequential history of the Science Awakening in the field of mathematics—philosophic pursuits that occurred in the world during the Pythagorean period, is the ancient Jaina School of Vardhamāna Mahāvira.

In Chapter I of this book, the author quotes Lincoln as saying, "The dogmas of the quiet past are inadequate to the stormy present" and states that the science awakening round about the period of Vardhamāna Mahāvira and Gautam Buddha, was a simple rise above the inadequacy of the scientific knowledge which became indispensable according to the needs of the times throughout the world." This science awakening covered many fields including Astronomy and Cosmology by framing the concepts of the universe to which the Jaina School contributed a lot after the era of the Vedāṅga Jyotiṣa and prior to

the Siddhāntic period of Indian astronomical atmosphere and continued through Ptolemy (c. 150 A. D.), Āryabhaṭa First (c. 498 A. D.), Copernicus (c. 1500 A. D.), Galileo (c. 1600 A. D.), Newton (c. 1680 A. D.), Einstein (c. 1925 A. D.), Eddington (c. 1925 A. D.) and many other Indian and foreign scholars and scientists. Sometimes the scientists had to pay very dearly for telling the truth. Regarding the solar system, Copernicus was the first western scientist who declared in very clear terms his assertion, "We therefore assert that the centre of the earth, carrying the moon's path, passes in a great orbit among the other planets in an annual revolution round the sun; that near the sun is the centre of the universe and that whereas the sun is at rest, any apparent motion of the sun can be better explained by motion of the earth." Galileo, a practical scientist accepted the Copernican theory and had to pay dearly through his trial, insult and imprisonment. Einstein theory of gravitation resulted in two types of universes; Einstein's closed spherical universe containing matter but no motion and the other the de Sitter universe containing motion but no matter. But as we know, the actual visible universe contains both matter and motion. According to Eddington, the universe is expanding till one comes to a de Sitter's universe (motion but no matter) while according to Hoyle, the concept of universe involves a continuous creation of matter, otherwise due to the condensation of the background material into galaxies, a dead state of universe may occur in future. Thus even during the modern advanced scientific age, the scientists are not unanimous in their theories about the nature of the Universe.

According to the Jaina School, it has been made undoubtedly clear that there are six eternal fluents (dravyas), viz, bios (souls), pudgala (pudgala paramāṇus or ultimate particles of matter), time particles (kālaṇus), aether (dharma), anti-aether (adharmā) and space (ākāśa); further the space has been divided into two types, viz, finite non-empty space, containing all the remaining five fluents) called Lokākāśa (universe-space) and the infinite 'all-empty space' (containing nothing except the space itself,) called Alokākāśa (non-universe space). The Lokākāśa has a volume of 343 cubic rajjus (a measure developed and defined specially by the Jainas) and as mentioned above, accommodates all the remaining five fluents, viz, souls (jīva-bios), pudgala (matter), dharma (of cooperator motion), adharmā (of cooperator rest) and kāla. It is situated in the very central portion of the endlessly endless (unfinite) space surrounded on all sides by the infinite Alokākāśa. Thus the Jainas have propounded the theory of two types of universe, viz, Lokākāśa containing both matter and motion and Alokākāśa containing none of them. Further the Jaina literature describes various

sub-universes, for example, general universe, hellish universe, human universe, sub-human universe. god's universe and astral-universe, the three major division of the Lokākāśa being the upper, the intermediate and the lower universes. Further according to the Jaina Philosophy, the specific relation between the bios and matter is a Kārmic one and the dynamical laws are derivable only from the Kārmic relations.

Chapter II describes some of the terms related to the celestial sphere and celestial diagram as envisaged at present; this has been given in order to facilitate a comparison of the modern technical terms with those used in the ancient Jaina literature where the frame of reference of celestial coordinates is different.

In Chapter III, the author, while giving a very short description of the historical evolution of the astronomy of the Vedic era, the Vedāṅga era and the Astro-theoretical era, and of the Jaina School, based on the book, 'Indian Astronomy' by Shankar Balkrishna Dixit, mentions that the Vedic literature which is regarded as the oldest literature giving us information about the efforts of the ancient Indians, in compiling the contemporary knowledge, may be deemed to belong to the period from 2000 or 2500 B. C. to 500 B. C. or so (while Vedāṅga-Jyotiṣa belongs to later period and is not a work on Astronomy as it is essentially a five-year perpetual calendar meant for prediction of times for religious purposes). While considering the Jaina School, the author describes the source material, still available at present in the Jaina literature in spite of the fact that a major part of the ancient literature has been destroyed and is not available. The main authentic works available at present and relevant to Mathematics, Astronomy and Cosmology are Jyotiṣa-karaṇḍaka-prakīrṇaka (c.-3rd century), Tiloyapaṇṇatti of Yati Vṛṣabha (5th century A.D.), Gaṇitasāra-Saṃgraha and Jyotiṣa Paṭala of Mahāvīrācārya (c. 850 A. D.), Triloksāra (11th century A. D.),

Ṣaṭkhaṇḍāgama (c 2nd century A. D.) and its commentaries, Lokavibhāga, Sūrya-prajñapti, Candra-prajñapti, Jambūdvīpa prajñapti etc. A number of later writers and scholars, for example, Hemahaṃsasagaṇi, Rājāditya (c. +1120), Mahendra Sūri (c. +1370), Malayendu Sūri, Mahimodaya (c. 1665), Labdhicandra gaṇi (c. +1693), Bāghaji muni (c. +1720), Sumati haṛṣa (c. + 1626), Bhāvaprabha Sūri (c. +1711) and many more have written books and discussed therein various aspects of Astronomy and Cosmology.

In Chapter IV, the author has discussed and described many cosmological concepts. In Jaina literature, the space-measure, rajju, occupies an important place and has been defined in a number of ways.

Some definitions are very complicated to be deciphered or to be computed. Based on these and by comparing the volume of the finite universe of Einstein Theory of Relativity with the volume of the universe as given in Jaina literature, G. R. Jain has come to the conclusion that one rajju =  $1.45 \times 10^{21}$  miles based on Digambara School and equal to  $1.63 \times 10^{21}$  miles based on Svetāmbara School.

According to one definition of C. T. Colebrook, Jain also finds one rajju =  $1.15 \times 10^{21}$  miles roughly, but as pointed out by Muni Mahendra Kumar II and many other scholars, these values of one rajju can't be taken as accepted. Taking the same definition of Colebrook and interpreting it in two different other ways, Muniji finds that

$$\text{one rajju} = 7.44 \times 10^{\{1.47 \times 10^{196} + 20\}} \text{ miles.}$$

$$\text{or} = 4.00 \times 10^{\{1.8 \times 10^{245} + 3\}} \text{ miles.}$$

The author also remarks that the Tiloyapaṇṇatti gives a very vivid description of the shape and the volume of the universe (the Lokākāśa) and also about the volumes of the three types of layers of air and water vapour all round the universe, showing that there is no outer surface of the universe without these layers. The author further mentions that in the Jaina School, the concept of eight central space-points of the loka, as well as the movement of matter and souls along the world-lines subject to instantaneous conditions defines a coordinate frame of the universe, full of space-points or time points and there is no corner of the universe which is not reachable before four instants, thus speaking of the principle of least time or the principle of quickest approach and the principle of least path, thus conforming to the theory that amongst all movements, the nature selects only those which reaches the desired location with expenditure of least action (energy  $\times$  time).

Regarding the Yuga system in India, the author quotes Roger Billard and from his book, 'L' astronomie indienne investigation des textes Sanskrits et des données numériques, Paris' and states that for astronomical studies what was being done in Greece during the period 8th Century B. C. to 2nd Century A. D., was being done in India also and the Jaina School was further studying the maximum and minimum periods of life-time of human, sub-human, gods and hellish beings in terms of muhūrtas, palyas and sāgaras etc. In this very context, he gives the meaning of palya, sāgara and briefly discusses the concepts of kalpa and parāvartana periods and comparability so important in the Jaina School. In the end, the author summarises, "The Jaina universe (Lokākāśa) is finite, lying in the very central portion of all space, with non-material media of motion and rest which have specific functional character. Space is a fluent and time-particles

are also fluents. Motion of ultimate particles in an indivisible instant could be minimum (one space-point) and maximum (14 rajjus). For bonds of particles, snigdha and rukṣa could be associated with positive and negative charges. For Karmic bonds, yoga and kaṣāya bind a bios with niṣekas, measured through particle number, configuration, life-time and energy-level of impartation (pradeśa, prakṛti, sthiti, and anubhāga)."

In Chapter V, certain astronomical concepts, for example, precession of equinoxes general calendar as well as Indian Calendar (pañcāṅga) etc. have been discussed. The author also mentions, as it is well known, that the calendar adopted in Vedāṅga Jyotiṣa has something to do with that adopted in the ancient Prakrit texts and that there is a great similarity in the treatment of the heavenly bodies and their motion in practically all ancient Prakrit texts of the Jaina karaṇānūyoga group. In Hindu Calendar, 27 nakṣatras while in the Jaina Calendar 28 nakṣatras have been reckoned, the Jainas having added one more nakṣatra 'Abhijit'. The author also points out that considering certain aspects of the astronomical incidences, Lishk and Sharma have concluded that the probable period of the Jaina canon may be about 6th Century B. C.

In Chapter VI, kinematics of the astral bodies have been discussed as available in ancient texts of India, China, Greece, Egypt, Babylonia etc. As stated by Needham and Ling, "In these texts there is never any mention of any Zodiac or of constellation lying along the ecliptic; the earliest documentary evidence of this conception occurs just after. On the other hand, seleucid cuneiform texts of the 3rd and 2nd centuries B. C., give great prominence to the Zodiac and use ecliptic coordinates extensively." But the author (Jain) points out that the above authors do not appear to have gone into details of the nakṣatra system of the Jaina School. The Zodiac of the Jaina School was so predominant that every nakṣatra of the Zodiac had its sign and Yogatārās. However, there is some difference of sign of the Zodiac in the two Jaina texts, the Candraprajñapti and the Tiloyapaṇṇatti, the reason may be that the, Candraprajñapti was based on observations taken in the north while Tiloyapaṇṇatti belonged to the observations taken in the south of India.

The commentaries of Candraprajñapti by Malayagiri and Amolak Ṛṣi give greater details of a Jaina Calendar based on calculation of motion of various heavenly bodies, specially that of the sun, the moon and the nakṣatras while Tiloyapaṇṇatti, Trilokasāra, Lokavibhāga and Jambūdvīpa prajñapti give concise knowledge of the same. According to Neugebauer, only since the Assyrian period, a turn towards mathematical description became visible and texts based on a consistent mathematical theory of lunar

and planetary motion came into existence only during the last three centuries B. C. In this connection it has been pointed out that the Jaina School had already developed a mathematical theory of the motion of heavenly bodies by the early centuries B. C., though as Yati Vṛṣabha mentions in his Tiloyapaṇṇatti that by his time, the description of the motion of the planets had become extinct but whatever remained in Candraprajñapti, Sūryaprajñapti, or Tiloyapaṇṇatti, clearly proves that the Jaina School was in possession of a complete calendar based on a highly developed ingenious and original mathematical theory. This is clear even from the example that the total number of astral images was given by the Jaina School as the quotient set obtained by dividing the square of the Jagaṣṛeni (set of points) by the product of the set of the squared finger width and the square of 256. The Jaina School also believed that the distribution of the astral objects was symmetrical and based on five kinds of astral-groups, viz., the moon, the sun, the planets, the constellations and scattered stars (prakīṛṇaka tārās) and that the moon was the head of the family of eighty-eight planets, twenty-eight nakṣatrās and 66975 (10)<sup>14</sup> stars.

As mentioned in this very Chapter, the Jaina School also believed that the phenomena of the heavenly events in all the islands was also symmetrical and could be represented by those, occurring in the Jambūdvīpa island only except that in far off islands, the astral bodies were assumed at rest. From this it is clear that such a symmetry denotes the manipulation of the causality theory through an abstract mathematical model, principle theoretic in nature and consistent. It is also remarkable to find that like other world traditions, the Jaina tradition also believed in shadow invisible planets as found in the texts Jinendramālā and Jñānapradīpikā. In the end of the Chapter, topics, like motion of astral bodies, relative motion of the nakṣatras, the relative motion of the sun and the relative motion of the moon have been described.

In Chapter VII, the author gives a vivid description of the various meanings and measures of a 'Yojana' as stated by a number of different schools and scholars, for example, the Chinese School, the Jaina School, Needham and Ling, Lishk and Sharma, Muni Mahendra Kumar II, Megasthenes (3rd - 4th centuries B. C.) etc. In the Jaina School and in some other systems, the Yojana has been taken as primarily depending upon aṅgula and equal to 768000 aṅgulas. But only in Jaina School, there are 3 types of yojana depending upon 3 types of aṅgulas—ātmāṅgula, utsedh-āṅgula, and pramāṇāṅgula which are used for measuring different types of objects as indicated in all concerned literature. The ātmāṅgula is used to measure the lengths of ornamental objects, gardens, cities, and residences

etc. belonging to human beings while utsedhāṅgula is used to measure the heights of sub-human and hellish objects and the cities and residences of four types of gods. In Śvetāmbara School, 1000 utsedhāṅgulas while in Digambara tradition, 500 utsedhāṅgulas are taken equal to one pramāṅgula. Thus according to the Śvetāmbara tradition, the pramāṅga yojana is equal to modern 8000 miles while the Digambara pramāṅga yojana comes out to be equal to 4000 miles and is used to measure the regions, the islands, the oceans, the high mountains, rivers etc., described in the Jaina cosmology. The Buddhist School takes its own aṅgūli-parva equal to two aṅgūlas of the Jainās. The Chinese generally take one yojana equal to 30 li or equal to 6.12 miles, they also take a yojana equal to 40 li or even equal to 16 li only. The concept of yojana occurs in Sūryasiddhānta also and according to Vācaspati and Śabdārṇava koṣas, a yojana may be taken equal to 5 miles as pointed out by Dixit. Fleet and Cunningham have estimated one yojana equal to  $9\frac{1}{2}$  miles and 6.7 miles respectively, the former value being accepted by L. C. Jain, the author of the present text while the latter value being accepted by Lishk and Sharma. Thus we find that a yojana is taken equal to different measures, by different texts and scholars, generally also depending upon its use.

Based on the concepts of the Jaina School, Lishk and Sharma have calculated the obliquity of the ecliptic as  $23^{\circ} 5'$  (in structure of the mathematical model of Meru) very close to the modern value. They have also calculated the maximum north polar distance of the moon from the sun or ecliptic as  $7.7^{\circ}$  which may however approximate to the modern value  $5^{\circ} 8' 40''$  if a yojana is taken equal to 5 miles.

In Chapter VIII, the author mentions about the calendrical yuga system. As stated by him, the various Indian Schools including the Jaina School accepted the quinquennial yuga or cycle but as pointed out by the author, this yuga (or cycle) began with the nakṣatra, Abhijit, a concept found in the Jaina School. This cycle was found to be of 780 solar years or 285480 days (one solar year=366 days).

In the last Chapter on Astronomical Theory, the author discusses many important modern concepts in the light of the concepts given in the Jaina literature. He quotes Albert Einstein as distinguishing between the various types of theories in Physics, specially the Principle Theories and the Constructive Theories. The Principle Theories, which are based on analytic methods, are logically perfect and have a secured foundation while the Constructive Theories follow the synthetic methods and could be made complete, clear and adaptable. However, if a single principle fails or if a

single inconsistency arises, the whole structure has to be re-modelled, because of almost impossibility then to retain its originality while the constructive theories can be subjected to re-modelling without shattering the complete structure.

The author further discusses to which type of the above two categories, the ancient Jaina Astronomical Theory belong. On one hand the abstraction method leads us to such small entity as the Samaya (समय) and Pradeśa (प्रदेश) which are both regarded as indivisible just like the ultimate particle Paramāṇu, while on the other hand there are such big quantities as the Rajju and Sāgara or Jagaśrēni and the periods like Puḍgala or Bhāva Parāvartana, infinities in space and time. Most of the Jaina Astronomical principles have been found to be true but in some cases, for example, in the prediction of the time of eclipses, when the Jaina Principle Theory was found inadequate to explain and get consistent results of the natural processes and phenomena, it was replaced by the Constructive theories evolved all the world over. Lastly the author discusses the evolution of epicycles depicting the unified motion of the moon or the sun as described in Prakrit texts and comprising the two motions, (i) the rotation of the earth, which in turn relatively gives a kinetic view of them, and (ii) their motion along the fixed stars.

Due to the continuity of the motion in circles, for each day, with a radius varying from day to day, the geometrical figure of the path comes out to be a spiro-elliptic one, winding and unwinding represented by the equation  $r = \frac{f+g\theta}{h+k\cos\theta}$ . The dynamical laws of Newton, Einstein etc. have been found from this equation.

In the end the author has given very useful and brief bibliographies of the source material, research articles and related books. Thus we see that the author has tried and tried very successfully, to give as much information and exposition as possible about the ancient Jaina Astronomical and Cosmological systems and other allied world systems, which is very praiseworthy and creditable.

Prof. L.C. Jain has got a keen interest not only in the study of the ancient Indian Mathematical and Astronomical works in general and the Jaina works in particular but also in the study of modern mathematics. He has got a vast experience of about three decades in this field and has himself brought out a large number of expository, survey and research articles on ancient Jaina mathematics, quite a good number of them dealing with the modern aspects inherent in the ancient Jaina principles.

It is hoped that this work of Prof. Jain would prove to be a very useful source of reference for any future work in this field.

G. C. PATNI

Ex. Prof. and Head of Deptt. of  
Mathematics and Dean, Faculty of  
Science and Faculty of Social Sciences,  
University of Rajasthan, Jaipur

Jaipur,  
20th Dec., 1983

# THE JAINA SCHOOL OF EXACT SCIENCES

## PART II

# COSMOLOGY AND ASTRONOMY

### CHAPTER I

## INTRODUCTION

“Give me to learn each secret cause;  
Let Number’s, Figure’s, Motion’s laws  
Reveal’d before me stand;  
These to great Nature’s scenes apply,  
And round the globe, and through the sky,  
Disclose her working hand.”

—Akenside, M.

According to Lincoln, “The dogmas of the quiet past are inadequate to the stormy present.” The Science awakening, round about the period of Vardhamāna Mahāvīra and Gautama Buddha, was a simple rise against the inadequacy of the scientific knowledge which became indispensable according to the needs of the times, throughout the world.

One has to see with supreme clarity and certainty, whether during the hatching of a Science awakening, there has been a desperate attempt towards development of a scientific methodology. The methodology, usually, involves founding of general postulates or principles from which conclusions could be deduced. The principles are wormed out of nature by perceiving in comprehensive complexes of empirical facts and events certain general features (say, cycles of births and deaths, regeneration and degeneration, evolution as well as devolution) which permit of precise formulation. Then may follow inference after inference revealing unforeseen relations, extending beyond the province of the reality from which one started the method out of pre-scientific thought.

Thus there has been awakening in framing the changes in concepts of the universe, the astral-universe being only an observable part of it. The

stories of such awakening cover the role played by Lucretius<sup>1</sup> (—98 to—55), Ptolemy<sup>2</sup> (c+150), Copernicus<sup>3</sup> (+1473 to +1543), Galileo<sup>4</sup> (+1564 to +1642), Newton<sup>5</sup> (+1642 to +1727), Einstein<sup>6</sup> (+1879 to +1955), Eddington<sup>7</sup> (+1882 to +1944) and Hoyle<sup>8</sup> (+1915 to—...), All have left indelible marks in the history of astronomy and cosmology, and even before them all, one could discover out the Jaina system which also championed the science awakening for the cause of research on truth and non-violence, prior to the Siddhāntic period of Indian astronomical fervour, after the era of the Vedāṅga Jyotiṣa

## SCIENCE AWAKENING

Titus Lucretius Carus was a great poet of science, unparalleled in Rome, fighting fear of gods, of sin and death. He belonged to the class among whom was stated, “Then, my noble friend, geometry will draw the soul towards truth and create the spirit of philosophy, and raise up that which is now, unhappily, allowed to fall down.”<sup>9</sup> Lucretius argued,<sup>10</sup> “Bear this well in mind, and you will immediately perceive that nature is free and uncontrolled by proud masters and runs the universe by herself without the aid of gods. For who— by the sacred hearts of the gods who pass their unruffled lives, their placid aeon, in calm and peace!— who can rule the sum total of the measureless? Who can hold in coercive hand the strong reins of the unfathomable? Who can spin all the firmaments alike

- 
1. Vid. ‘Nature of the Universe’, trans. R. E. Latham, Penguin Books Ltd., 1951.
  2. Vid. ‘The Almagest’, trans. R. C. Taliaferro, ‘Great Books of the Western World’, series, vol. 16, Book I—Chicago, 1952.
  3. Vid. ‘De Revolutionibus Orbium Coelestium (1543)’, published by Royal Astronomical Society.
  4. Vid. ‘Dialogue concerning the two chief world systems— Ptolemaic and Copernican’, trans. Stillman Drake, Univ. of California Press, 1933.
  5. Vid. ‘Philosophiae Naturalis Principia Mathematica’, Drake, A. M., trans. rev. by F. Cajori, Univ. of California Press, 1946. (Cf. also *Mein Weltbild*, Amsterdam, 1934).
  6. Vid. ‘The World As I See It’, Newyork.
  7. Vid. ‘The Expanding Universe,’ Cambridge, 1933.
  8. Vid. ‘The Nature of the Universe’, New York, 1960.
  9. Cf. Coolidge, J. L., *A History of Geometrical Methods*, Oxford, 1940.
  10. Cf. ‘Nature of the Universe’, op. cit.

and foment with the fires of ether all the fruitful earths ? Who can be in all places at all times, ready to darken the clear sky with clouds and rock it with a thunderclap— to launch bolts that may often wreck his own temples, or retire and spend his fury letting fly at deserts with that missile which often passes by the guilty and slays the innocent and blameless ?”

Claudius Ptolemy of Alexandria, an astronomer of first rate, argued in the *Almagest*, the spherical movement of the heavens as follows, “If for example, one should assume the movement of the stars in a straight line to infinity, as some have opined, how could it be explained that each star will be observed daily moving from the same starting point ? For how could the stars turn back while rushing on to infinity ? Or how could they turn back without appearing to do so ? Or how is it they do not disappear with their size gradually diminishing, but on the contrary seem larger when they are about to disappear, being covered little by little as if cut off by the earth’s surface ?” His scheme served as a new edition of Hipparchus (c—2nd century), his universe being a geometrical pattern of epicycles, eccentrics and deferents. It neither opposed Aristotle nor the Bible and reigned supreme for 14 centuries till the advent of sun-centred scheme of Nicholas Copernicus. The work of Copernicus was declared false and altogether opposed to the Holy scripture by the Pope in +1616, (earlier in 1600, Giordano Bruno had been burnt for supporting the views). His assertion was, “We therefore assert that the centre of the Earth, carrying the Moon’s path, passes in a great orbit among the other planets in an annual revolution round the Sun; that near the Sun is the centre of the Universe; and that whereas the Sun is at rest, any apparent motion of the Sun can be better explained by motion of the Earth.” 11

Galileo Galilei, a practical scientist par excellence, had to pay dearly for accepting Copernicanism, because his experiment with falling bodies went against Aristotle and his telescope opposed the Pope and Ptolemy. An excerpt from his book on *Dialogue*, which led to his trial, insult and imprisonment, is as follows,” *Simplicio* : The first and greatest difficulty is the repugnance and incompatibility between being at the centre and being distant from it. For if the terrestrial globe must move in a year around the circumference of a circle— that is, around the Zodiac— it is impossible for it at the same time to be in the center of the Zodiac. But the earth is at that center, as is proved in many ways by Aristotle, Ptolemy, and others. *Salviati* : Very well argued. There can be no doubt that any one who wants to have the earth move along the circumference of a circle must

---

11. Cf. *De Revolutionibus*, op. cit.

first prove that it is not at the center of the circle. The next thing is for us to see whether the earth is or is not at the center around which I say it turns, and in which you say it is situated. And prior to this, it is necessary that we declare ourselves as to whether or not you and I have the same concept of this center. Therefore, tell me what and where this center is that you mean."<sup>12</sup>

It was left for the genius of Isaac Newton to formulate the laws of celestial mechanics in the *Principia* on the basis of the works of Galileo, Kepler, and Tycho Brahe, consistent with the Copernican system. Discussing about the absolute and relative, true and apparent, mathematical and common, Newton writes, "Absolute time, in astronomy, is distinguished from relative by the equation or correction of the apparent time. For the natural days are truly, unequal, though they are commonly considered as equal and used for a measure of time; astronomers correct this inequality that they may measure the celestial motions by a more accurate time. It may be that there is no such thing as an equable motion whereby time may be accurately measured. All motions may be accelerated and retarded, but the flowing of absolute time is not liable to any change."<sup>13</sup>

Albert Einstein contributed to relativistic mechanics replacing Newtonian space-time by a super-edifice of four-dimensional continuum on the basis of Riemannian geometry and tensor calculus of Levi Civita. Writing on the fundamentals of theoretical physics, he explains, "The general theory of relativity owes its origin to the attempt to explain a fact known since Galileo's and Newton's time but hitherto eluding all theoretical interpretations: the inertia and the weight of a body, in themselves two entirely distinct things, are measured by one and the same constant, the mass. From this correspondence follows that it is impossible to discover by experiment whether a given system of coordinates is accelerated, or whether its motion is straight and uniform and the observed effects are due to a gravitational field (this is the equivalence principle of general relativity theory). It shatters the concepts of the inertial system, as soon as gravitation enters in. It may be remarked here that the inertial system is a weak point of the Galilean-Newtonian mechanics. For there is presupposed a mysterious property of physical space, conditioning the kind of coordinate-systems for which the law of inertia and the Newtonian law of motion hold good."<sup>14</sup>

Einstein's theory of gravitation on introduction of a cosmological term results in two types of universes; Einstein's closed spherical universe

---

12. *op. cit.*

13. Cf. *Principia Mathematica*, *op. cit.*

14. Einstein, *Ideas and opinions*, London, 1956, p. 330.

and the de Sitter universe. Einstein's universe contains matter but no motion, whereas the de Sitter's universe contains motion but no matter. The actual universe, however, contains both matter and motion. Eddington's study has given rise to an expanding universe, till one finishes up in a de Sitter's universe. Hoyle's theory, in addition, postulates a continuous creation of matter in order to compensate for the condensation of the background material into galaxies, otherwise a dead state of the universe in future is the consequence.

## JAINA COSMOS

The Jaina school has clearly distinguished between all empty space and non-empty space, the former being *alokākāśa* (non-universe-space) and the latter being *lokākāśa* (universe-space).<sup>15</sup> *Alokākāśa* extends to infinity all around beyond the finite *lokākāśa* which has a volume of 343 cubic *rajjus* (ropes).<sup>16</sup> The *lokākāśa* accommodates the five eternal fluents (*dravyas*), viz., souls, ultimate particles of matter (*pudgala paramāṇus*), time particles<sup>17</sup> (*kāḷāṇus*), aether (*dharma*) and anti-aether (*adharmā*); space (*ākāśa*) being the sixth eternal fluent. The *lokākāśa* is situated in the very central portion of the endlessly endless empty-space. Souls are infinite, and endless times this infinity is the cardinal number of the set of time-particles, situated at every space-point (*pradeśa*). Space-point is the space occupied by an ultimate particle at rest, which by virtue of its motion may occupy more than one space-point in an indivisible instant (*avibhāgi samaya*). Thus *pradeśa* and *samaya* are the ultimate units of space and time<sup>18</sup>, the *samaya*

- 
15. Vid. T. P., I, vv. 1.91 et seq. Cf. also G. A., pp. 1, et seq. Vid. also *Cosmology, old and new by Jain, G. R., Indore, 1942. See appendix A and appendix B for the shape of the universe in Digambara School. In the other it contains steps all around.*
16. Cf. T. P., I, vv. 1.133 et seq. According to *Śvetāmbaras*, 239 c. r.
17. *Siddhasenagaṇi* regards time as a modification of bios & matter. In *Śvetāmbara* work *Jivā jivābhigama*, the same view is expressed, but in *Bhagavati* and other works, time has been regarded as a separate fluent. "Kālaścetyeke", in *Śvetāmbara and Kālaśca*" in *Digambara*. Cf. Kirfel, *Die Kosmographie der Inder*, Bonn, 1920.
18. Time (*Kāla*) has been defined to be of two types : *niścaya* and *vyavahāra*. *Niścaya* (absolute) time is a fluent, whereas *vyavahāra* (relative) time is a measure. Similarly *niścaya* (absolute) space is a fluent, where as *vyavahāra* (relative) space is a measure. "Aṇoraṇvantara vyatikrama kālaḥ samayaḥ. Coddasa rajjuāgāsa padesa kamaṇa metta Kāleṇa jo Coddlasā rajju kamaṇakkhamo paramāṇū tassa ega paramāṇuakkameṇa kālo samao ṇāma." Cf. *Dhavalā*, book 4; 1, 5, 1, p. 318, *Ṣaṭkhaṇḍāgama*.

being the interval in which an ultimate particle crosses another ultimate particle or else is able to cross all space-points situated in a stretch of fourteen rajjus.

Rajju is a familiar historical word from Egyptian rope-stretchers. Through it are measured the distances between the ends of the immense universe (loka), the *cardinal number* of space-points of which is *innumerate*, as also of those of a fully stretched soul, of the aether and of the anti-aether as well as of the time-particles.

Out of all these fluents, only the matter ( pudgala ) has been endowed with five types of taste, five types of adour, five types of colours, and eight types of touch. The ultimate particle, has however, only one taste, one odour, one colour, two types of touch (either cold or hot, and either smooth or rough). Smoothness or roughness has been associated with levels from zero to infinity, corresponding well with positive and negative types of charges in so far as their story of bonds is concerned in Jaina literature. One may call the touch to be of affine and anti-affine types, again corresponding with love and malice of a bios, or affinity and anti-affinity, causing karmic (action) bonds between a bios and ultimate-particles.<sup>19</sup> Thus pudgala is material, other fluents being abstract. Motion is defined for the bios and matter alone, the other fluents being stationary, ākāśa being an accommodator, kāla being a modifier, dharma being motion-cooperator, and adharma being rest-cooperator. Consciousness is accorded to the bios alone.<sup>20</sup>

Common properties or controls of all the fluents are interesting :

- i) Astitva (existence): signifying it as eternal and indestructible
- ii) Vastutva (objectivity): signifying it as having some norm of action.
- iii) Dravyatva (fluence) : signifying it as being, flowing through its own controls and events.
- iv) Prameyatva ( measurability ) : signifying that it could be the subject of knowledge.

---

19. Cf. P. A., vv. 127-134.

A fluent (dravya) is that which flows through its own controls (guṇas) and events (paryāyas). Each is endowed with regeneration, degeneration and immutability (utpāda, vyaya evam dhrauvya).

20. These describe the special properties or controls (guṇas) of the six fluents.

- v) Agurulaghutva ( non-gravity-levity ) : signifying the power by virtue of it, the fluent does not lose its own controls and remains always what it is.
- vi) Pradeśatva ( pointedness ) : signifying that every fluent has some or other form (shape, size, etc.)

Further, space (ākāśa) forms a continuum absolutely, but relatively it consists of or is composed of infinite space-points (pradeśas) whose cardinality is greater than that of the instants (samayas) in the past, the present and the future. Similarly the cardinality of the infinity of the time-instants is greater than the cardinality of the set of all ultimate particles (paramāṇus).<sup>21</sup> Matter, souls, aether, anti-aether and space are each called astikāya because each of them is many-pointed. Soul may contract or expand, forming a continuum. Aether and anti-aether also form a continuum. Time-particles do not form astikāya in so far as each is single pointed and discrete, <sup>22</sup>

In the works on karaṇānuyoga, description of various subuniverses is available. For example in the Tiloyapaṇṇatti, chapters have been devoted to the general universe, hellish universe, human universe, sub-human universe, astral universe, and gods universe.<sup>23</sup> Loka is also of four types : fluent (dravya), quarter (kṣetra), time (kāla) and phase (bhāva) universes.

Thus under various controls of their own, the fluents modify themselves through various types of events. The specific relation between the bios and matter being karmic one. The astral universe relates the astronomy in terms of celestial parts (gagana khaṇḍas), project-measure (yojana), and forty-eight-minute set (muhūrta),<sup>24</sup> The dynamical laws are derivable only from the *Karmic (action) relations*, as it appears, which may be subject to deeper probe, later. Yojana may be compared with Chinese 'li'

21. Cf. D., book 3, p. 30, 31.

22. All the six types of fluents (in various number) enter each other, continually mixing with each other, accommodating each other mutually, yet do not lose their own nature (special property).

23. Cf. T. P., I & II. The three major divisions are the upper, intermediate and lower universes. Cf. also G. A., p 9.

24. Cf. ibid. Cf. also S. P., C. P., T. S., and L. V.

## 2. TECHNICAL TERMS

For an interesting reading, it is desirable to acquaint the readers with certain terms used in astronomy at present, so that the ancient material could be brought under relevance.

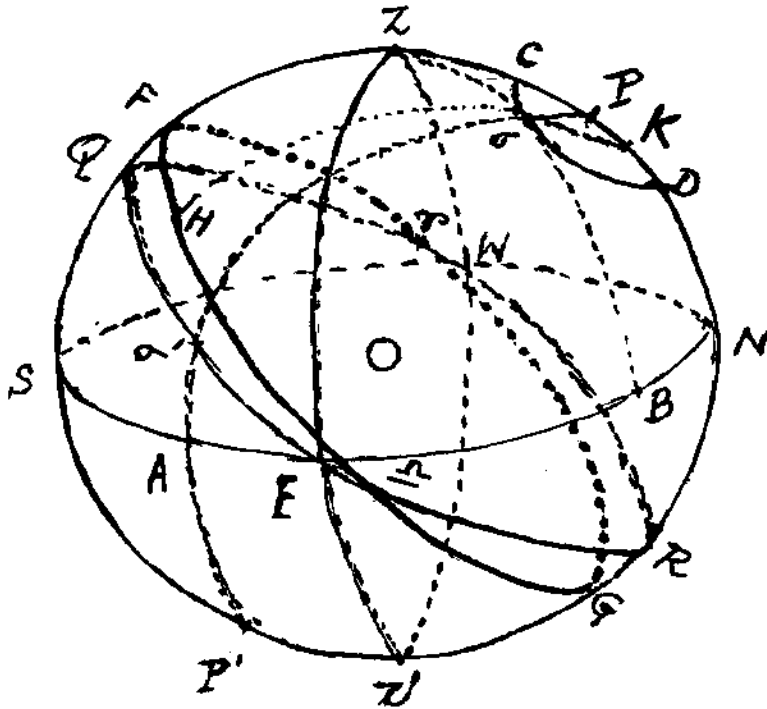

### CELESTIAL DIAGRAM

The above is a *celestial diagram* used in spherical trigonometry and astronomy. An observer is set at O inside a hollow sphere, serving as two hemispherical domes, with Z as the Zenith and Z' as the nadir. This is presumed to be his range of vision in which all the heavenly bodies appear in different positions, measured through various types of celestial coordinates. S N is his horizon, with East (E), West (W), North (N), South (S) as its

cardinal directions. Above N in the northern direction is the Pole star (roughly) or the celestial pole at P, the south celestial pole being at P'. All are great circles with O as centre and O N as radius, except the  $C_{\sigma}D$  which is a small circle, with P as its Pole.

Z E Z' is the prime-vertical East, and Z W Z' is the prime-vertical West. The perpendicular to the polar axis and  $P_{\sigma}\sigma'P$  is the celestial equator Q E R W. The secondary to this is the  $P_{\sigma}\sigma'P'$ . Here  $\sigma$  is any star whose declination is  $\sigma'\sigma$ , the declination circle being  $C_{\sigma}D$ .

The celestial equator cuts the ecliptic  $F \triangle G \varphi$  (path of the sun) at  $\triangle$  and  $\varphi$ , called the first point of Libra and the first point of Aries, or the equinoctial points. The position of the sun at these points make days and nights equal all over the earth. The pole of the ecliptic is denoted by K, near P.

The circle  $P_{\sigma}\sigma'P'$  may be called the hour circle as it measures the hour angle of the star's movement from the celestial meridian PZSP', always westwards, from  $O^h$  to  $24^h$  or  $O^{\circ}$  to  $360^{\circ}$ . Thus the declination  $\sigma'\sigma$  and hour angle Z  $P_{\sigma}$  as subtracted from  $360^{\circ}$  gives a system of celestial coordinates measured with the help of celestial equator and its secondary.

A second system of coordinates is set up from the ecliptic  $F \triangle G \varphi$  and its secondary through  $K_{\sigma}H$ . Here  $H_{\sigma}$  is called the celestial latitude of the star  $\sigma$ , and the angle at K, measured eastwards from  $\varphi$  between the secondaries K  $\varphi$  and  $K_{\sigma}H$  to the ecliptic is celestial longitude of the star.  $\varphi Q_{\sigma}'$  measures the right ascension of  $\sigma$ <sup>25</sup>.

The angle between the ecliptic and the equator is  $23\frac{1}{2}$  degrees and is the same as the arc P K. The distance N P gives the altitude of the pole star or latitude of the observer. This is also equal to ZQ. Now F and G are solstitial points, when the sun is nearest or farthest from the earth.

When the star is at C, it is said to culminate or at upper meridian transit, at D it is at lower transit.  $\sigma B$  is the altitude of the star  $\sigma$ , and Z $\sigma$  is its zenith distance.

25. Right ascension and declination forms another system of celestial coordinates.

## INDEX OF THE DIAGRAM

O	Observer
S E N W	horizon, with south, east, north, west as cardinal points at S, E, N, W.
Z	Zenith
Z'	nadir
Z E Z'	prime vertical east
P Z Q P'	celestial meridian
P	north celestial pole
P'	south celestial pole
Q E R W	celestial equator
F $\simeq$ G $\varphi$	(celestial) ecliptic (path of the sun along zodiac)
P N	altitude of pole star or latitude of the place.
K	pole of the ecliptic
$\simeq$	first point of Libra
$\varphi$	first point of Aries
	} Equinoctial points
F & G	solstitial points
$\sigma$	star, with its path C $\sigma$ -D, declination circle.
P $\sigma$ $\sigma'$ p'	Secondary to celestial equator or hour circle.
K $\sigma$ H	Secondary to ecliptic
$\sigma$ B	altitude of star $\sigma$
Z $\sigma$	zenith distance of star $\sigma$
$\sigma'$ $\sigma$	declination of star $\sigma$
Z P $\sigma$	360° minus the hour angle of star $\sigma$
F Q or F $\simeq$ Q	obliquity of ecliptic (23½°)
H $\sigma$	celestial latitude of star $\sigma$
$\varphi$ F H	celestial longitude of star $\sigma$
$\varphi$ Q $\sigma'$	right ascension of star $\sigma$
C	point of culmination of star $\sigma$
A	point of intersection of hour circle with horizon.

It is now important to note how various positions of the heavenly bodies were depicted in the Jaina school. Concepts were the same, but the frame of reference of celestial coordinates was different. The researches of Lishk and Sharma <sup>26</sup> are attracting attention of scholars in so far as their interpretations are bringing the secrets of the school to light in terms of modern usage.

---

---

26. Cf. bibliography of research papers.

### 3. SOURCE MATERIAL

Shankar Balkrishna Dixit, in his *Indian Astronomy*<sup>27</sup> has given the historical evolution of the astronomy into three stages : Vedic era, Vedāṅga era, and Astro-theoretical era.

#### VEDIC LITERATURE

As is well known, the Vedic literature<sup>28</sup> is regarded as the oldest literature as well as the outstanding effort of the ancient Indians towards collection of the contemporary knowledge, leaving apart the still unknown treasures of the civilization of the Indus valley, or of the pre-Harappan cultures. The three distinct classes of this literature are the Saṃhitās (the Ṛgveda, the Sāmaveda, the Yajurveda and the Atharvaveda), the Brāhmaṇas (Aitareya, Kauṣītaki, Pañcaviṃśā, Jaiminiya, Kaṭha-fragment, Taittirīya, Śatapatha, and Gopatha), as well as the Āraṇyakas-Upaniṣads (forest texts and secret doctrines; including Chāndogya, Kena, Mahānārāyaṇa, Śvetasvatara, Maitrāyaṇī, Bṛhadāraṇyaka, Īṣā, Muṇḍaka and Praśna).

According to Winternitz, the view on Vedic chronology generally followed is, "we shall probably have to date the beginning of this development about 2000 or 2500 B. C. and the end of it between 750 and 500 B. C."<sup>29</sup> During this period, the times of occurrence of the parvas ("Knots of time"), viz., full moon, new moon, equinoxes, solstices etc. were investigated for religious performances. Dixit have tried to find out relevant astronomical details in various parts of the literature.

---

27. Cf. *Bhāratīya Jyotiṣa*, Hindi trans. by S. N. Jharkhandi, Lucknow, 1975.

28. Cf. Bose, D.M., Sen, S. N., Subbarayappa, B. V, *A concise History of Science in India*, New-Delhi 1971.

29. Max Müller holds the view that the oldest of the Vedas could not have been composed earlier than 1200 B. C. Hermann Jacobi and B. G. Tilak, on the basis of precession, etc. opine this date to be in the third millennium B. C. Cf. *ibid.* pp. 22-23.

## VEDĀNGA JYOTISA

The next group of literature comes under the Vedāngas comprising of Śikṣā, kalpa, vyākaraṇa, nirukta, chandaḥ and jyotiṣa. The jyotiṣa is found in recensions of the Ṛga and the Yajurvedas: Arc-jyotiṣa and Yajuṣa-jyotiṣa. The Atharva-jyotiṣa, astrological in character belongs to a later date. These works take the winter solstice at the time of Sun and Moon's conjunction as the first point of the Dhaniṣṭhā (a point of the ecliptic lying 193° 20' east of the star Zeta Piscium). The epoch might be 1400 B. C. From the lengths of the day and night at summer solstice, viz. 36 and 34 ghaṭis, it may be inferred that the author belonged to a place in latitude 35° north (near north of Kashmir, in India).<sup>30</sup> According to Shukla, the Vedānga-Jyotiṣa is not a work on astronomy, but it is essentially a five-year perpetual calendar meant for prediction of the times for religious purposes, and that the Vedānga calendar had two main defects. Actually there are 1826-2819 civil days in a 5 solar year period (yuga), and not 1830 days (as supposed in the Vedānga Jyotiṣa), therefore, after every new cycle, the winter solstice fell about 4 days earlier.

Moreover, as there are 1830 8964 days in a period of 62 lunar months and not 1830 as supposed in the text, a deficit of one tithi approximately in a period of 5 solar years resulted.<sup>31</sup>

## JAINA TRADITION

The Jain school is said to have tradition of twenty-four tirthaṅkaras, Mahāvira was the last. The name of the first tirthaṅkara, Ṛṣabhadeva, appears in Vedic literature, Bhāgavat purāṇa and even in Shiva mahāpurāṇa. Dr. H. L. Jain presumes that there was a parallel Śramaṇa tradition to the Vedic tradition. The ascetics of the former were called Munis and those of the later as Ṛṣis, and that there could have an exchange of knowledge between both the traditions.<sup>32</sup> The historicity of Pārśvanātha

---

30. Cf. Shukla, K. S., *Astronomy in India before Aryabhaṭa-I*, paper read at B. G. P., Lucknow. Cf. also Renouf, L., and Filliozat, J.—L' *Inde classique*, École Française d'Extrême-orient, Hanoi, 1953; they find the text to be of c. 400 B. C., but the astronomical elements belong to the period of the Saṃhitās. Cf. also, Dixit, op. cit., p. 126. et seq.

31. The Vedānga calendar consisted of 61 civil, 62 lunar, and 67 sidereal months. A solar day, reckoned from sun rise to another, the year consisted of 366 civil days. This calendar commenced on the first tithi of the white half of the month Māgha.

32. Cf. Bhāratiya Saṃskṛti men Jaina Dharma kā Yogadāna, Bhopal, 1962, pp. 11 et seq.

tirthaṅkara has also been established, the nirvāṇa of Mahāvīra being accepted as —527. The bifurcation of Jaina tradition of literature into that of Śvetāmbara and of Digambara appears to be round about +73.<sup>33</sup>

## LITERATURE IN 'SVEĀMBARA SCHOOL

A question may be posed whether there was any literature of the Jaina School prior to Mahāvīra? Two types of scriptures, dravya and bhāva, in Jaina tradition, has been described according to its worded or else thought, or normed. The later may be brought under the caption of the pūrvas (the earlier). Fourteen such pūrvas of knowledge of the tradition are described as utpāda pūrva, agrāyaṇīya, vīryānuvāda, astināstipravāda, jñāna pravāda, satya-pravāda, ātma pravāda, karma pravāda, pratyākhyāna, vidyānuvāda, kalyāṇavāda (or abandhya, according to Śvetāmbara), prāṇāvāya, kriyā viśāla and lokabindusāra. Mention has been made from place to place in available Jaina literature about these pūrvas, still they are said to have become extinct about 162 years after Mahāvīra. By this very time, the Śvetāmbara tradition is said to have held a conference of Jaina Śramaṇas in Paṭliputra at the instance of Sthūlabhadra and compiled the eleven aṅgas of āgama : āyārāṅga, śhaṇṇāṅga, samavāyāṅga, viyāha-paṇṇatti, nāyādhammakahāo, uvāsagadesāo, antagaḍadasāo, aṇuttarovāya dasāo, panhavāgaraṇa and vivāga suyam. The twelfth aṅga was diṭṭhivāda (having five divisions—parikarma, sūtra, pūrvagata, anuyoga and cūlikā), excepting perhaps a part of pūrvagata of which, rest material is not available.

Apart from the above, the council of Valabhi, at the instance of Devaṛddhi Gaṇi (c. +454) compiled twelve upāṅgas, six cheda sūtras, four mūla sūtras, ten prakīrṇakas and two cūlikā formulas.

*Upāṅgas* : aupapātika, rāyapascqiyam, jivājivābhigama, prajñapanā, sūryaprajñapti, jambūdvīpa prajñapti, candraprajñapti, kalpikā, kalpāvateṃsikā, puṣpikā & vṛṣṇidaṣā,

*Chedasūtras* : niśītha, mahāniśītha, vyogahāra, ācāradaśā, kalpasūtra and pañcakalpa,

*Mūlasūtras* : uttarādyayana, āvaśyaka, deśavaikālika, and piḍḍaniryukti.

*Prakīrṇakas* : catuḥ śaraṇa, ātura-pratyākhyāna, mahāpratyākhyāna, bhaktaparijñā, tandula vaicārika, samstāraka, gacchācāra, gaṇividya, devendra stava, & maraṇasamādhī,

*Cūlikāsūtras* : nandī sūtra and anuyogadvāra.

33. Cf. Jain, J. P., "The Jaina Sources of the History of Ancient India, (100 B. C. to A. D. 900)", Delhi (1964).

## LITERATURE IN DIGAMBARA SCHOOL

The Digambara tradition, however, regards a part of agrāyaṇi-pūrva, Ṣaṭkhaṇḍāgama (c. + 2nd century), as well as a part of jñānapravāda, Kasāyapāhuḍa sutta (c. + 1st century), to be authentic compilation. Other works appear to be those of Kundakunda (c. + 5th century). The Karaṇā-nuyoga group of Digambara literature is known to be in Lokavibhāga (present edition of + 11th century), Tiloyapaṇṇatti (c. + 5th century), Trilokasāra (c. + 11 century) and Jambūdvīpaprajñapti (c. earlier to + 1461).

## CERTAIN CONTRIBUTORS

The Karaṇānuyoga group of Śvetāmbar literature may also found to be in kṣetra samāsa, saṃgrahaṇi of Jinabhadraṇi. These have been modified and extended as Bṛhatkṣhetra samāsa and Bṛhaṭ saṃgrahaṇi (compiled by Candrasūri of + 12th century). Then there are Laghukṣetra samāsa of Ratnaśekhara (c. + 14th century), Bṛhatkṣetra samāsa of Somatilaka (c. 14th century), vicārasāra prakaraṇa of Devasūri (c. 13th century), and Jyotiṣa karaṇḍaka-prakīrṇaka (c.—3rd century ?)

Nemicandra Sastri, in his Bhāratiya Jyotiṣa, mentions some astronomical texts of astro-theoretical era, compiled by Jaina astronomers. He mentions Mahāvīrācārya to have compiled Jyotiṣapaṭala which is available in part, relating motion, state and number etc. of planets, constellations and stars.<sup>34</sup> He regards Śrīdhara, the compiler of Jyotir-jñānavidhi, to have become Jaina in later years. Udayaprabhadeva sūri (c. + 1220) is said to have compiled ārambhasiddhi (vyarahāra caryā); whose commentator Hemahaṃsagaṇi appears to have some prakrit text on planetary mathematics with him. A kannaḍa astronomer; Rājāditya (c. + 1120) appears to have compiled mathematical texts applicable to astronomy. Mahendrasūri (c. + 1370) completed a work on Yantra rāja, on various celestial diagrams, commented by his disciple, Malayendusūri.<sup>35</sup>

Contributions to astronomy may also be mentioned of Mahimodaya's pañcāṅgāyana vidhi (c. + 1665), Labdhicandraṇi's janmapatri paddhati (c. + 1693), and Bāghajīmuni's tithisāriṇi (c. + 1726). Karṇakutūhala vṛtti of Sumatiharṣa (c. + 1626), Mahādevi Sāraṇi vṛtti of Dhanarāja (c. + 1635), Grahalāghava vṛtti of Yaśasvatasāgara (c. + 1703), Jyotirvidā bharaṇa vṛtti of Bhāvaprabha Sūri (c. + 1711), Candrārki vṛtti of kṛpāvijayā, may also be mentioned.<sup>36</sup>

The contribution to astrology has been excluded in the above.

34. op. cit. p. 91.

35. Published at Bombay, 1936.

36. Cf. Nahata, A.C., Jaina Jyotiṣa aurā Vaidyaka Grantha, Śrī Jaina Siddhānta Bhāskara, vol. 4, no. 2, 1937, pp. 110-118. Cf. also, Jain, A., Some Unknown Jaina Mathematical works (Hindi), Gaṇita Bhārati, 4:1-2 ( 1982 ), 61-71.

## 4. COSMOLOGICAL CONCEPTS

Certain fundamental ideas have already been related in the introduction. The first curiosity is now as to what is a rajju through which the enormous distances of the ends of the loka (universe) are measured.

### EVALUATION OF RAJJU

In some Jaina works, a rajju is defined as the diameter of the Svayambhūrāmaṇa ocean<sup>37</sup>. In Ratnasañcaya prakaraṇa, a rajju is defined as follows : "A god can go 100,000 yojanas in the winking of an eye. The distance travelled by him, thus in 6 months is a rajju."<sup>38</sup>

Rajju has also been defined as follows :

"If a powerful god were to throw down forcibly an iron ball heated and weighing one thousand bhāras, the distance which it could travel in six months, six days, six praharas, and six ghaṭikas is equal to a rajju,"<sup>39</sup>

G. R. Jain, however, opines that the above definition can not be subject to computation, for the law of the falling of bodies is not known. He goes further to correlate the radius of finite universe of Einstein's theory of relativity, with the rajju as follows :<sup>40</sup>

---

37. Cf. L. P.. (I, v. 65).

38. Joaṇa lakkha pamāṇam,  
Vimesa mitteṇa jāi jo devo.  
Chammāseṇa ya gamaṇam,  
Eyam rajjū pamāṇeṇam. || 483 ||. ( Cf. R.S.V., P. 483, p. 189 )

39. Mīlhai suhumāi koi suro,  
A golo a ayamao ḥiṭṭho,  
Bhāra saḥassamayam so,  
Chammāse chahim diṇehim pi. ||19||  
Cha pahare cha ghadiya,  
Jāvakkammai jaivi evaiyā.  
Rajjū tatth pamāṇo,  
Divasamuddā havai eya. ||20|| Cf. R. S. P., vv. 19,20.

40. Cf. Cosmology, old & new, op. cit. pp. 105-117.

Radius of the universe = (1068 million) (light years)  
 = (1068 × 10<sup>6</sup>) (5.88 × 10<sup>12</sup> miles)

Volume of the spherical universe (by formula  $\frac{4}{3} \pi r^3$ )  
 =  $\frac{4}{3} \pi (1068 \times 10^6 \times 5.88 \times 10^{12})^3$  cu. miles  
 = 1037 × 10<sup>63</sup> cu. miles —(A)

The volume of the loka = 343 cu. rajjus —(B)

Equating (A) and (B), one gets

One rajju = 1.45 × 10<sup>21</sup> miles —(E)

From Śvetāmbara measure, the volume = 239 cu. rajjus —(C)

Equating (A) and (C), one finds

One rajju = 1.63 × 10<sup>21</sup> miles —(F)

Now, Jain further takes the definition of a rajju according to Colebrook, as the distance which a deva (god) flies in six months at the rate of 2,057,152 yojanas in one kṣaṇa (instant).<sup>41</sup> He takes a big yojana to be 4000 miles, hence the distance travelled in six months, or one rajju,

= 2057152 × 4000 × (6 months) miles.

= 2057152 × 4000 × 6 × 30 × 24 × 60 × 54000 miles<sup>42</sup>

= 1.15 × 10<sup>21</sup> miles roughly. —(G)

The comparison between (F), (G) and (H) gives the evaluation of a rajju, subject to controversial points. The value of a yojana is to be discussed later in detail, as it carries a great historical importance.

## VOLUME OF UNIVERSE

Regarding the volume of universe, Muni Mahendra Kumar II agrees with the Digambara tradition, as the squared loka measure does not signify the cubic loka measure and hence the volume as 343 cubie rajjus is confirmed to be same in both traditions.<sup>43</sup> Regarding the evaluation of the

41. Quoted by Von Glassnapp in "Der Jainismus" Berlin, 1925,

42. Taking an instant to be a prativilāṃśā,, Jain

finds 60 prativilāṃśās = 1 prati vipala,

60 prati vipalas = 1 vipala

60 vipalas = 1 pala

60 palas = 1 ghati = 24 minutes

∴ 1 minute = 54000 prativilāṃśā and so on,

43. Cf. Viśva Praheḷikā, Bombay, (Hindi), 1969, pp. 93-101.

Cf. also Loka Prakāśa, ch. 12, vv. 110 to 115, by Vinaya Vijayagaṇi, and also vv. 116 to 137, Pts I, II, Surat, 1932, Pt. III, Bhavnagar, 1933.

rajju, Muni Mahendra Kumar II, goes still further and first finds the value of Śiṛṣa prahelikā :<sup>44</sup>

Māthuri vācanā,  $7.58 \times 10^{193}$

Vālabhya vācanā,  $1.87 \times 10^{249}$

Using the Māthuri vācanā value, he finds the least yoked innumerate (jaghanya yukta asaṃkhyāta to be  $(7.58 \times 10^{193})^{(7.58 \times 10^{193})}$ , i.e. the value raised to its own power, or multiplied as many times as it is. This gives the number of instants in an āvalikā.

Now 1 muhūtra = 48 minutes = 1,67,77,216 āvalikās  
and 6 months = 5400 muhūrtas.

This, ultimately leads to the value of a rajju, as per definition of Colebrooke to be

1 rajju =  $1.86 \times 10 \{ (1.47 \times 10^{196}) + 17 \}$  yojanas.

When a yojana is taken to be 4000 miles, then

1 rajju =  $7.44 \times 10 \{ (1.47 \times 10^{196}) + 20 \}$  miles

=  $1.45 \times 10 \{ (1.45 \times 10^{196}) + 8 \}$  light years.

#### ANOTHER VALUE OF RAJJU <sup>45</sup>

There is one more basis on which the value of rajju could be calculated. If the number of the continuous stretch of the islands and oceans upto the Svayambhūramaṇa ocean, in the intermediate universe (madhya loka) is taken to be n, then the following equation gives the value of a rajju :

$$\log_2 (\text{rajju}) = n + (1 \text{ or } \text{Saṃkhyāta}) + \log_2 (\text{diameter of Jambūdvīpa}),$$

where n could be related as

$$n - 5 = \left\{ \log_2 \frac{\text{rajju}}{240 \text{ pramāṇāṅgula}} \right\} - \text{Saṃkhyāta}, \quad \text{..... (I)}$$

Now the total number of astral bodies are given to be

$$\left( \frac{7 \text{ rajjus}}{256 \text{ pramāṇāṅgula}} \right)^2 \div \frac{1}{1655361} \quad \text{..... (II)}$$

which may be calculated to be approximately as

$$\left( 6.69 \times 10^{18} \right) \left[ 64 \left[ \frac{176}{3} \left\{ 2^{(n-5)} \right\}^2 - 2^{(n-5)} - 57 \frac{2}{3} \right] \right] \quad \text{..... (III)}$$

the value of a rajju could be calculated by equating I and III.

44. Cf. V. P., pp. 116 - 119.

45. Cf. T. P. G., pp. 99-102.

Muni Mahendra kumar II, has approximately calculated this value to be

$$1 \text{ rajju} = 4.00 \times 10 \{ (1.8 \times 10^{245}) + 3 \} \text{ miles}$$

by taking the same values of Śīrṣaprahelikā and yojana as mentioned earlier. <sup>46</sup>

He has concluded that the volume of the universe, thus, could not be less than

$$(10) 10^{196} \text{ cubic miles.}$$

The figures of the universe, given ahead, speak for themselves, the shape and the volume of the universe (loka). For details of the volumes of the three types of layers of air and water-vapour, all around the universe, the Tiloyapaṇṇatti gives very vivid description, showing that there is no outer surface of the universe without these layers.<sup>47</sup>

### FRAME OF DESCARTES

Descartes (+ 1596 to + 1650), a soldier and mathematician desired only tranquillity and repose. He emphasized order and measure in mathematics and discovered coordinate geometry, from which algebraic equations could be framed for a curvilinear path of a moving point.

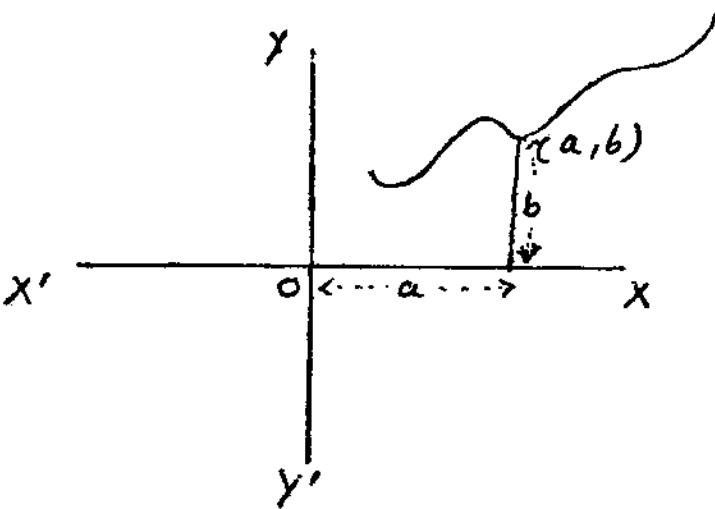

46. Cf. V. P., pp. 119-123.

47. Cf. T. P. G., pp. 36-39.

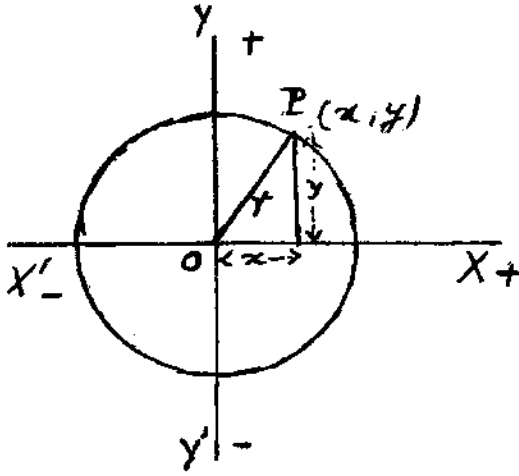

The point P moves in a circle of radius  $r$ , and its path equation is given by  $x^2 + y^2 = r^2$ .

According to Hankel, H., "The analytical geometry, as Descartes' method was called, soon led to an abundance of new theorems and principles, which far transcended everything that ever could have been reached upon the path pursued by the ancients."<sup>48</sup>

In the Jaina school, the concept of eight central space-points of the loka, as well as the movement of matter and souls along world-lines subject to instantaneous conditions define a coordinate frame of the universe, full of space-points or time-points as already described.

The deciding verses are : <sup>49</sup>

- 2·25. In transit from one body to another, (there is) vibration of the karmic body only.
- 2·26. Transit (takes place) in rows (straight lines) in space.
- 2·27. The movement of a (liberated) soul is without a bend.

48. Moritz, R. E., On Mathematics and Mathematicians, Dover, 1942, New York, p. 152,

49. 2·25 Vighrahagatau karmayogāḥ  
 2·26 Anuśreṇi gatiḥ  
 2·27 Avighrahā jīvasya  
 2·28 Vighrahavati ca saṃsāriṇaḥ prākcaturbhyaḥ  
 2·29 Ekasamayā avighrahā  
 2·30 Ekam dvau trīnvā anāhāraḥ

2-28 The movement of the transmigrating souls is with bend also prior to the fourth instant.

2-29 Movement without a bend (takes) one instant.

2-30 For one, two, or three instants ( the soul remains ) non-assimilative.

The above shows how a transmigrating soul or the matter associated with it moves from a loka-point to another loka-point, in any case, before four instants. In general, the three coordinates are needed for such a depiction :

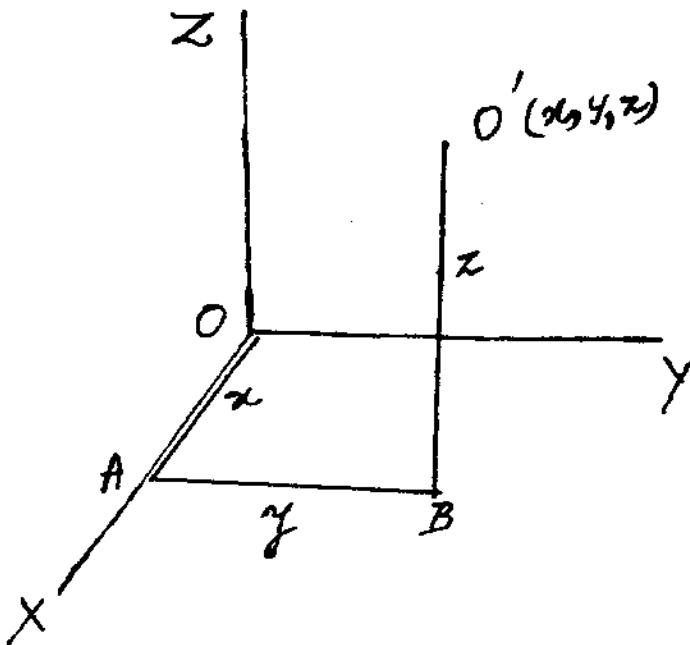

The movement of the body from O to O' involves three paths O A, A B, B O', each being traversed in an instant, thus three instants in all are involved in such a movement.

Thus there is no corner of the universe which is not reachable before four instants, the eight central points and the rows & columns of space-points making world-lines, or paths in the specific circumstances.

This speaks of the principle of least time, or the principle of quickest approach, from which could also be derived the principle of least path. It was believed that amongst all movements, the nature selects only those which reaches the desired location with expenditure of least action (energy  $\times$  time).<sup>49</sup>

## COSMIC PERIODS AND CYCLES

The Jaina literature, while depicting norms and measures of quantities pertaining to observable events (say, those of astronomy), stand

49. With these theories were connected the contributors Maupertuis (+1698 to +1759), Fermat (+1601 to +1665), Hamilton (+1805 to +1865), Jacobi (+1804 to 1851) and so on.

equally competent to express all these regarding non-observable events (pertaining to karmic phenomena), as well. The question is what was the source of inspiration of Yuga system in India. For what purpose their study was started from the time of Āryabhaṭa I (c. +5th century) and continued over for several centuries ?

## YUGA BHAGANA

Roger Billard<sup>50</sup> has tried to answer the above problem, and he opines as follows :

“For it is a mathematical method that has allowed us to go far beyond the best results of the scholarly studies in the field. Thanks to such an astronomical investigation of the Sanskrit texts and numerical data, our knowledge of Indian astronomy has just improved greatly. We do know now what was exactly the astronomical science in India and the hows and whens of its history. In particular we can see now how and why Āryabhaṭa is the leading figure in a strange and wonderful history of astronomy.

There is no need to recall here what are the yuga or the yuga-bhagaṇa, nor how the yuga prevailed on Indian astronomy. To tell the truth, with such common multiples of revolutions, of course devoid of physical meaning, and so huge periods and numbers, the Indian astronomy did look like a pure speculation, a wordy literature displaying astronomical elements of pure fancy.

Now the technical investigation of the yugabhagaṇa has revealed that they are not entirely devoid of reality. The very yuga proceed indeed from a speculation, but I can state that every set of speculative elements or, as we shall say henceforth, every yuga canon is always based directly or indirectly upon a set of astronomical observations, and obviously, on account of the yuga, solely upon one set of astronomical observations. This being so, by a wonderful paradox, it is the very fitting of a speculation upon reality that enables us to detect now the existence, the epoch and the quality of those observations, discover now the key of Indian astronomy, find the fin mot of the question. Thanks to the instrument with which probability theory provides us, many yuga canons afford at present a never-seen means of

---

50. Cf. L' astronomie indienne, investigation des textes Sanskrits et des données numériques, Paris, 1971.

Cf. also, “Āryabhaṭa and Indian Astronomy,” I. J. H. S.,

Vol. 12, no. 2, Nov. 1977, pp. 207-224.

Cf. also, Jaina, L. C., Āryabhaṭa-I and Yativṛṣabha a study in Kalpa and Meru, ibid., pp. 137-146.

mathematical investigation that brings the very numerical data to tell a chronology and a history of Indian astronomy for the most part unexpected till to-day.”

The above statement is one of the various aspects of reality, so seriously felt by Billard. According to him such observations are widely scattered from 721 B. C. to 141 A. D., in Greece. What was done in India during this dark period? The Jaina school was speculating the maximum and minimum periods of life-time of human, sub-human, gods, and hellish beings in terms of palyas, muhūrtas, sāgaras, and so on.

### CONCEPT OF PALYA AND SĀGARA

Let us just see the description of a palya,<sup>51</sup> “Palya is of three kinds, vyavahāra palya, uddhāra palya and addhāpalya. These are significant terms. The first is called vyavahāra palya as it is the basis for the usage of the other two palyas. There is nothing which is measured by this. The second is uddhāra palya, as the continents and oceans are numbered by the bits of wool drawn out. The third is addhāpalya. Addhā means duration of time.

Now the first palya is described. Three pits of the extent one yojana (consisting of 2,000 krośas) long, one yojana broad and one yojana deep, based on the measure of pramāṇāṅgula, are dug out. These are packed with the smallest ends of the wool of rams from one to seven days old, the bits incapable of being further cut by scissors. This is called vyavahāra palya. Then the small bits of wool are taken out one by one once in every one hundred years. The time taken for emptying the pits in this manner is called vyavahāra palyopama. Each bit is again cut into so many pieces as there are instants in innumerable crores of years. And (imagine that) with such bits the pits are filled up. This is called uddhāra palya. Then these bits are taken out one by one every instant. The time taken for emptying the pits in this manner is called uddhāra palyopama. Ten crores multiplied by one crore uddhārapalyas make up one uddhāra sāgaropama. The continents and oceans are as numerous as the bits in two and a half uddhāra sāgaropamas. The pits are filled with bits got from cutting each bit of uddhārapalya into the number of instants in one hundred years. This is addhāpalya. Then these bits are taken out one by one every instant. The time taken to empty the pits in this manner is called addhāpalyopama. Ten crores multiplied by one crore addhāpalyas make one

---

51. Cf. Jain, S. A., Reality—Eng. Trans. of Shri Pūjyapāda's Sarvārtha Siddhi, Calcutta, 1960, pp. 105-106.

addhā sāgaropama. One descending cycle of time consists of ten crores multiplied by one crore addhā sāgaropamas. The ascending cycle is of the same extent. The duration of karmas, the duration of particular forms, the lifetime and the duration of the bodies of the beings in the four states must be measured by addhā palya. This has been said briefly in the verse:

Vyavahāra, Uddhāra and addhā must be understood as three palyas, Vyavahāra palya is the basis of numeration. The enumeration of continents and oceans is by the second. The duration of karmas is reckoned by the third addhāpalya.<sup>52</sup>

Further,  $10^{14}$  vyavahāra palyopama = 1 vyavahāra sāgaropama  
 $10^{14}$  uddhāra palyopama = 1 uddhāra sāgaropama  
 $10^{14}$  addhā palyopama = 1 addhā sāgaropama.<sup>53</sup>

It is further important to note how the time-instants and space-points cardinals of these big units are correlated as follows<sup>54</sup>:

Set of points in finger width

$$= [ \text{Set of instants in Palya} ] [ \log_2 (\text{set of instants in Palya} ) ]$$

Set of points in stretch of world line ( Jaga Śreṇī )

$$= \left[ \frac{\log_2 (\text{set of instants in Palya} )}{\text{innumerate}} \right] \\ = \left[ \text{Set of points in cube of finger} \right] \\ \text{width}$$

## CONCEPT OF KALPA

There are two regions, Bharata and Airāvata where there is

- 
52. Numerically, vyavahāra palyopama =  $4.13 \times 10^{46}$  years,  
 Uddhāra palyopama =  $(4.13 \times 10^{46}) \times$  ( innumerate crore years of  
 instants ) Samayas.  
 Addhā palyopama = (Set of instants in uddhāra palyopama)  
 $\times$  (Set of instants in innumerate crore years).
53. Cf. T. P. G., p. 22. Cf. also V. P., for variations in Śvetāmbara tradition, pp. 245-248.
54. Cf. T. P. G., p. 22.

regeneration and degeneration<sup>55</sup> in the knowledge, longevity, stature etc. during six periods of the two aeons of regeneration and degeneration, known as utsarpiṇī (hyperserpentine) and avasarpiṇī (hyposerpentine). The full cycle takes 2014 addhā sāgaropoma of time.<sup>56</sup> The present period is speculated to be Duṣṣamā, consisting of 21000 years of avasarpiṇī, leading to gradual degeneration, ending in + 18497 of the Christian era.

## PARĀVARTANA PERIODS

Then the periods of cycles of wandering or transmigration of a bios based on transmutation, transfer, and other changes attract attention at the speculation of the Jaina school. The transmigration is of five kinds : (1) cycle of material change (2) cycle of spatial change (3) cycle of temporal change (4) cycle of incarnation change and (5) cycle of becoming (phase) change.<sup>57</sup>

The description of the cycle of phase ( bhāva ) is interesting and hence it may be lucidly related here. The period of time taken in the completion of such a cycle is really strange to imagine. Let some bios be endowed with the five senses and the mind and actuated by mythic faith acquires knowledge—obscuring karmas, below  $(10^7)^2$  sāgaras duration, which is the utmost minimum and suited to it. The minimum degree of passion suited to that duration, governed by the six stations<sup>58</sup> and of the extent of innumerate times the innumerate space—points of loka, occurs to him. And, owing to this minimum degree of affection (Kaṣāya), the minimum degree of intensity (impartation) of karmas of the extent of innumerate times the spatial units of the universe occurs to him. In this manner, the utmost minimum degree of vibratory (volition) activity occurs to this bios with the minimum duration, the minimum of affection, and the minimum of impar-

55. Cf Reality, op. cit. p. 97. Cf. also Cosmology, old & new, op. cit. p. 231. G. R. Jain, here, finds the value of the mahākālpa of the two aeons avasarpiṇī & utsarpiṇī, each of which consists of  $4.13 \times 10^{76}$  solar years. The Brahma kālpa also consists of 77 digits but digits do not agree.

56. Cf. V.P., pp. 129–134, for details.

57. These are called dravya, Kṣetra, kāla, bhava and bhāva parāvartana. Cf. Reality, pp. 56–60.

58. Cf. Cosmology, Old & New, op. cit., pp. 100–103. The increase and decrease is in infinitesimal, innumerate part, numerate part, numcrate times, innumerate times and infinite times of intensity as an impulse.

tation. The second degree of vibration activity, which occurs to the bios with the same duration, degree of affection and degree of impartation intensity, is accompanied by an increase of innumerate part. Similarly the third, fourth, etc. degrees of vibratory activity must be understood. All these degrees of vibratory (Yoga) are governed by the four stations<sup>59</sup> and are accompanied every time by an increase of innumerate part of Jaga śreṇi.

Thus the second degree of impartation occurs to the bios having the same duration and the same degree of affection. Its degrees of Yoga<sup>60</sup> must be understood as before, The three things are constant. But the degrees of Yoga are accompanied by an increase of innumerate part of the height of loka (14 rajjus). Similarly for the third, fourth, etc., degrees of impartation upto the limit of innumerate times the space-points of loka. The purport here is that the duration and degree of Kaṣāya are at minimum. But the degrees of impartation (anubhāg) gradually increase upto the extent of innumerate times the space-points of loka.

For the increase of each degree of impartation there is an increase of Yoga to the extent of innumerate part of the height of universe. Similarly, the second degree of Kaṣāya occurs to the bios having the same duration. For this also, the degrees of impartation and the degrees of Yoga must be understood as before. For the increase of each degree of Kaṣāya, there occurs an increase in the impartation to the extent of innumerate part of loka. For the increase of each degree of impartation, there is an increase of Yoga of the extent of innumerate part of height of loka. Thus, gradually from the third degree of kaṣāya upto the limit of innumerate times the space-units of loka is to be understood. Similary for the increase of one instant to minimum duration is ascertained. Then for every duration, with the increase of one instant at a time, upto maximum limit of thirty sāgaropama koṭā koṭi is reached, the degrees of kaṣāya etc. is ascertained. Increase & decrease in six stations & four stations ( which exclude infinitesimal part and infinite times). This is to be ascertained for all types and subtypes of karmas. All these combined constitute the cycle of phase<sup>61</sup> ( bhāva ).

59. As described above.

60. Yoga is the vibratory activity of mind, larynx, and body limbs. Kaṣāya is the activity of affection. Yoga is kinetic or tends to be kinetic, where as kaṣāya (Moha disposition) is potential or tends to be potential. Moha is divided into vision (delusion) and disposition.

61. For details of other cycles of particular remaining changes, of Reality; op. cit., pp. 56-60.

## COMPARABILITY

*Comparability of the above Periods.*<sup>62</sup> It may be noted that

- (1) In the past, the cycles of phase (bhāva) changes are minimum.
- (2) The cycles of incarnation changes are infinite times the cycles of phase changes.
- (3) The cycles of temporal changes are infinite times the cycles of incarnation changes.
- (4) The cycles of spatial changes are infinite times the cycles of temporal changes.
- (5) The cycles of material changes are infinite times the cycles of spatial changes.

Now the comparability is as follows for the cycles :

- (i) The period of material change is minimum.
- (ii) The period of spatial change is infinite times the period of material change.
- (iii) The period of temporal change is infinite times the period of spatial change.
- (iv) The period of incarnation change is infinite times the period of temporal change.
- (v) The period of phase (bhāva) change is infinite times the period of incarnation change.

It may further be mentioned that regeneration, degeneration and immutability (permanence) of a fluent every instant prevails. These ensure its existence or being which is the characteristic of a fluent (dravya).<sup>63</sup>

Thus we find that the Jaina universe is finite, lying in the very central portion of all space, with non-material media of motion and rest

---

62. Cf. D., book 4, p. 334, for details of ardhā pudgala parivartana, cf. *ibid.*, 324-332. For further details, cf. G. J. K., v. 560, commentary.

63. Utpāda vyaya dhrauvya yuktam sat. 5.30. Sad dravya lakṣaṇam. 5.31. Cf. Reality, op. cit., ch. 5, vv. 30-31.

which have specific functional character. Space is a fluent, and time-particles are also fluents. Motion of ultimate particles, in an indivisible instant could be minimum ( 1 point ) and maximum ( 14 rajjus ). For bonds of particles, snigdha and rukṣa could be associated with positive and negative charges. For karmic bonds, yoga and kaṣāya bind a bios with niṣekas, measured through particle number, configuration, life-time and energy-level of impartation ( pradeśa, prakṛti, sthiti and anubhāga )

---

## 5. ASTRONOMICAL CONCEPTS

There is a strange similarity in treatment of the heavenly bodies and their motion, practically, in all the available ancient Prakrit texts of the karaṇānuyoga group, related earlier. From the following tables, it appears as if the calendar adopted in the Vedāṅga Jyotiṣa has something to do with that adopted in Prakrit texts :

### PRECESSION OF EQUINOXE

*Calendar of the Vedāṅga Jyotiṣa*

Year	Sun's northerly course	Sun's northerly course	Moon's northerly course	Sun's southerly course	Sun's southerly course	Moon's southerly course
	Month & Tithi	Sun's Nakṣatra	Moon's Nakṣatra	Month & Tithi	Sun's Nakṣatra	Moon's Nakṣatra
I	Māgha white I	Dhaniṣṭhā	Dhaniṣṭhā	Śrāvana white 7	Āśleṣā-rdha	Citrā
II	Māgha white 13	„ „	Ārdrā	Śrāvana dark 4	„ „	Pūrvā Bhādrapad
III	Māgha dark 10	„ „	Anurādhā	Śrāvana white 1	„ „	Āśleṣā
IV	Māgha white 7	„ „	Aśvini	Śrāvana white 13	„ „	Pūrvā Āśāḍha
V	Māgha dark 4	„ „	Uttarā Phālguni	Śrāvana dark 10	„ „	Rohiṇī

64. Cf. Dixit, op. cit., p. 101,

Year	Sun's northerly course	Sun's southerly course				
Month & Tithi	Sun's Nakṣatra	Moon's Nakṣatra	Month & Tithi	Sun's Nakṣatra	Moon's Nakṣatra	
I	Māgha dark 7	Abhijit	Hasta	Śrāvaṇa dark 1	Puṣya	Abhijita
II	Māgha white 4	.. ..	Śatbhiṣā	Śrāvaṇa dark 13	.. ..	Mrgśira
III	Māgha dark 1	.. ..	Puṣya	Śrāvaṇa white 10	.. ..	Viśākhā
IV	Māgha dark 13	.. ..	Mūla	Śrāvaṇa dark 7	.. ..	Revatī
V	Māgha white 10	.. ..	Kṛttikā	Śrāvaṇa white 4	.. ..	Pūrvā Phālgunī

From the above two tables, it is quite clear that the Sun, which was touching the southern most point in the Dhaniṣṭhā has shifted to some point in the (added twenty eighth) constellation Abhijit. This is the phenomenon of precession of equinoxes, when seasons begin to change, and is of 360° in 26000 years.

That is the first point of Aries itself moves at this rate which is approximately 72 years 2 $\frac{2}{3}$  months for every degree of its precession<sup>66</sup> towards

65. Cf. C. P. Sūtra 12.5, pp. 536-556. Cf. also. T. P., II, ch. 7, vv. 526-536, pp. 748-749.

66. Precession is said to have been discovered by astronomer Hipparchus (fl. 146-127 B. C.). This is about 50'' .26 in celestial longitude per year. K. S. Shukla points out the first point of Dhaniṣṭhā to be 193° 20' east of star zeta-Piscium, when the sun, Moon's conjunction at winter solstice occurred about -1400. He further finds the first point of Abhijit to be 175° 55' 10'' east of star zeta-Piscium, when the Sun, Moon's conjunction at winter solstice occurred about -146. However, by a process of counting how many times the same themes have been repeated in the various Jaina canonical texts, Jacobi and Schubring concluded that the most ancient portions of the canon were composed during -3rd & -4th centuries [Cf. Renou, L, etal, L' Inde Classique (1953, pp. 616-617. ]

west along the ecliptic. Now the shift from Dhantīṣṭhā (  $\beta$  Delphini ) of the sun's winter solstice to Abhijit (  $\alpha$  -Lyrae ) is about 1703', according to Prof. Thibaut. This means that the observations of the above calendrical phenomena were made after a difference of about 1231 years.

Various dates have been suggested about the Vedāṅga Jyotiṣa; Colebrooke H. T. : (C.-1108), Max Müller : (-3rd century), Weber, A. : (C.+5th century).

## DATE OF ADOPTION OF CALENDAR

Lishk and Sharma<sup>67</sup> have pointed out an important fact about the first point of Aries, "It may also be noted that no reference has as yet been found to point out that the order of rāśis (signs) began from a sign other than Meṣa (sidereal Aries) or the Meṣa sign began from a nakṣatra (asterism) other than Aśvini ( $\beta$  Arietis). There is no doubt that these terms denoting elliptic signs were not current in Vedāṅga Jyotiṣa period. Probably these terms came into vogue when Vernal equinox occurred in Aśvini ( $\beta$  Arietis) nakṣatra (asterism) and Meṣa sign (sidereal Aries) at that time. The tropical longitude of the star  $\beta$  arietis, the identifying star of Aśvini, was 31° 53' and that of Arietis, 35° 34' in 1850 A. D. Hence the years when the tropical longitudes of these stars were zero, can be worked out, taking 72 years for 1° precession as follows :

$$31^{\circ} 53' \times 72 (= 2296) - 1850 = 446 \text{ B. C.}$$

and  $35^{\circ} 34' \times 72 (= 2561) - 1850 = 711 \text{ B. C.}$

The mean of these dates is 579 B. C.

Since the winter solstice in Abhijit (Lyrae) corresponds to Vernal equinox in Aśvini ( $\beta$  Arietis), probably it was the period when reckoning of first point of the zodiacal circumference was shifted from winter solstice to Vernal equinox. Thus in the light of this discussion, the probable period of Jaina Canon may be assigned to about 6th century B. C."<sup>68</sup>

- 
67. Lishk, S. S., & Sharma, S. D., Sources of Jaina Astronomy, Jaina Canonical Literature, Jaina Antiquary, 29-2, 19-32, 1976.
68. The eighth equinox occurs, on the white 15 of Vaiṣākha at the conjunction of Aśvini nakṣatra, after lapse of 93 parvas from the beginning of Yuga. ( T. P., pt. II, v. 7:544, p. 750), Trilokasāra ( v. 426) mentions the white 15 of Vaiṣākha as dark 1 of Vaiṣākha.

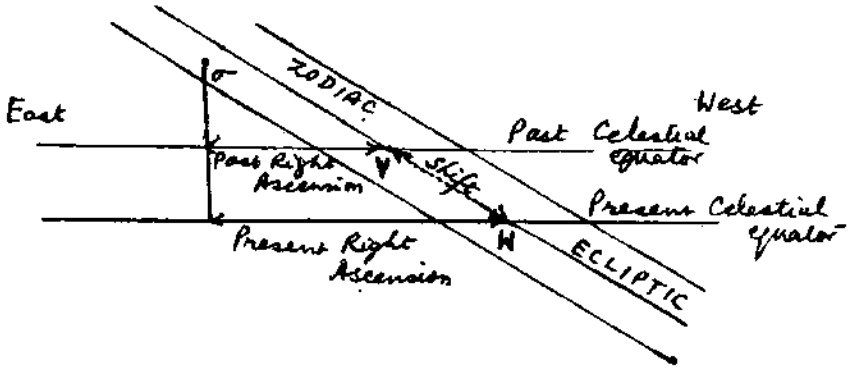

The above diagram shows how the Vernal equinox goes on shifting ( from V to W ), along the ecliptic ( the path of the Sun ), and how it makes change in right ascension and declination of a star.

## PANĀĀNGA

*Certain technical terms used in calendar :*

Pañcāᅅga is the name given to Indian calendar as it comprises of five types of information which is either collected or calculated on the basis of observations of heavenly bodies and certain theories or formulas developed in due course of time for mechanical manipulation of the data.

Before one goes into details of motion of heavenly bodies, usually kinematical in ancient texts, one has to be familiar with the terms frequently used in advanced theories of astronomy gradually evolved & developed by the ancient people for practical purposes of growing crops, regularizing duties, economizing time and then optimizing their own operations. This might have led them to speculative sports and games of adventurous nature for which statistics and probability in form of astrology, numerology, and so on might have evolved although they could not become the exact sciences, even till today, for their involvement into endless calculations needed in their quasi-theories.

Pañcāᅅga means five parts :

*Tithi* : The longitudes of the sun and the moon are measured from  $\gamma$  ( first point of Aries ) towards east along the ecliptic, and the difference of these longitudes determine the tithi. First tithi ( pratipadā ) lasts till the difference lies between  $0^{\circ}$  and  $12^{\circ}$ , the second tithi lasts till the difference lies between  $12^{\circ}$  and  $24^{\circ}$ , and so on. In a lunar month, there are thirty tithis.

A tithi is measured in ghaṭi and pala. A muhūrta equals 48 minutes, or 2 ghaṭis, or 120 palas. A day of 24 hours equals 30 muhūrtas. Thus a ghaṭi is of 24 minutes. The origin of time is regarded from the instant of sun-rise on a particular day. In the pañcāṅga, if the time shown for the tithi is 5 ghaṭis 12 palas, it will signify that the tithi will end at 5 ghaṭis 12 palas, after the sunrise for the day. The tithis are of unequal duration, due to non-uniform motion of the sun and the moon. The Kṛṣṇa pakṣa and śukla pakṣa, each consists of 15 tithis.

**Vāra** : Any day of the week is called vāra, and it begins with the rise of the sun and ends after 24 hours.

**Nakṣatra** : In Jaina calendar the ecliptic is divided into 28 unequal parts, and each is called a nakṣatra. The sidereal period of the moon is about  $27\frac{1}{3}$  days, a nakṣatra is described in about a day by the moon. Apart from the 27 nakṣatras of the Hindu astronomy, the Jainas added Abhijit nakṣatra. When the moon is in Abhijit, it means that duration itself lasts as the Abhijit nakṣatra name. The time of birth goes with the moon's position in a nakṣatra, where as the time of a season goes with the sun's position in a nakṣatra. The instants, when the moon crosses or transits from one nakṣatra to another are shown in the Pañcāṅga.

## GRADUATION OF CELESTIAL SPHERE

The Jaina calendar divides the whole stretch of the heaven into 54900 celestial parts (gagana khaṇḍas) which may be kept equivalent to  $360^{\circ}$  of the modern celestial or armillary sphere. A measure of a sign of Zodiac is  $30^{\circ}$ , and that will be equivalent to 4575 celestial parts (abbr. c. p.) The correspondence between stretches of the nakṣatra and Zodiacal constellations in terms of celestial parts and the duration for which they remain with the moon and the sun work out as follows.<sup>69</sup>

---

69. Cf. T. P., II, ch. 7, specially, vv. 478-488. Cf. also S. P., op. cit.

No.	Name of constellation	Stretch in celestial parts	Stretch of Zodiac in c. p. from and upto	Duration for which Moon is with constellation		Duration for which Sun is with constellation		Linear Velocity in Yojanas of constellation in a Muhūrta
				Muhūrta	67 Part	Day	Muhūrta	
1	Aśvini	2010	Aries from 0 on wards	30	0	13	12	5265 $\frac{18263}{21960}$
2	Bharaṇi	1005	Aries continued	15	0	6	21	5265 $\frac{18263}{21960}$
3	Kṛttikā	2010	Aries upto 4575 and Taurus 0 upto 450	30	0	13	12	5285 $\frac{37}{594}$
4	Rohiṇi	3015	Taurus continued	45	0	20	3	5288 $\frac{20377}{21960}$
5	Mṛgśirā	2010	Taurus upto 4575 and Gemini 0 upto 900	30	0	13	12	5319 $\frac{15998}{21960}$
6	Ārdrā	1005	Gemini continued	15	0	6	21	5319 $\frac{15998}{21960}$
7	Punārvasu	3015	Gemini upto 4575 and cancer 0 upto 345	45	0	20	3	5273 $\frac{11403}{21960}$
8	Puṣya	2010	Cancer continued	30	0	13	12	5319 $\frac{15998}{21960}$
9	Āśleṣā	1005	Cancer continued	15	0	6	21	5319 $\frac{15998}{21960}$
10	Maghā	2010	Cancer upto 4575 and Leo 0 upto 795	30	0	13	12	5273 $\frac{11403}{21960}$

11	Pūrvā Phālguni	2010	Leo continued	30	0	13	12	5265	18263
12	Uttarā Phālguni	3015	Leo upto 4575 and Virgo 0 upto 1245	45	0	20	3	5265	18263
13	Hasta	2010	Virgo continued	30	0	13	12	5319	15998
14	Citrā	2010	Virgo upto 4575 and Libra 0 upto 690	30	0	13	12	5288	20377
15	Svāti	1005	Libra continued	15	0	6	21	5265	18263
16	Viśākhā	3015	Libra upto 4575 and Scorpio 0 to 135	45	0	20	3	5292	16947
17	Anurādhā	2010	Scorpio continued	30	0	13	12	5300	10454
18	Jyēṣṭhā	1005	Scorpio continued	15	0	6	21	5304	7024
19	Mūla	2010	Scorpio upto 4575 and Sagittarius 0 to 585	30	0	13	12	5319	15998
20	Pūrvāṣādhā	2010	Sagittarius continued	30	0	13	12	5319	15998
21	Uttarāṣādhā	3015	Sagittarius upto 4575 & Capricorn 0 to 1035	45	0	20	3	5319	15998
22	Abhijit	630	Capricorn continued	9	27	4	6	5265	18263

No.	Name of constellation	Stretch in celestial parts	Stretch of Zodiac in c. p. from and upto	Duration for which Moon is with constellation		Duration for which Sun is with constellation		Linear Velocity in Yojanas of constellation in a Muhūrta
				Muhūrta	67 Part	Day	Muhūrta	
23	Śrāvaṇā	2010	Capricorn continued	30	0	13	12	$\frac{18263}{5265}$ $\frac{21960}{21960}$
24	Dhaniṣṭhā	2010	Capricorn upto 4575 & Aquarius 0 upto 1110	30	0	13	12	$\frac{18263}{5265}$ $\frac{21960}{21960}$
25	Satbhiṣā	1005	Aquarius continued	15	0	6	21	$\frac{18263}{5265}$ $\frac{21960}{21960}$
26	Pūrvā-bhādrapada	2015	Aquarius continued	30	0	13	12	$\frac{18263}{5265}$ $\frac{21960}{21960}$
27	Uttarā-bhādrapada	3015	Aquarius upto 4575 & Pisces 0 upto 2565	45	0	20	3	$\frac{18263}{5265}$ $\frac{21960}{21960}$
28	Revatī	2010	Pisces upto 4575 and Aries 0	30	0	13	12	$\frac{18263}{5265}$ $\frac{21960}{21960}$

The above table proves the originality of the Jaina system. There were unequal divisions and unequal velocities of certain groups of constellations showing that their distances of the earth were taken to be different. The angular and linear velocities signify the complete manipulation of the motion.

## NOTE

*Yoga* : The sum of the longitudes of the sun and the moon, expressed in minutes of arc, as divided by 800, gives a quotient; next greater integer to which determines the serial number of yoga. In the *pāñcāṅga*, ending time of a yoga is given. In Jaina astronomy, however, the word yoga carries the meaning of kinematic appearance of the moon or the sun against the background of a *nakṣatra*.<sup>70</sup>

*Karaṇa* : Half of a *tithi* is a *karaṇa*. This is also not mentioned in the above texts.

*Lagna* : It is the point of intersection of the ecliptic with eastern horizon at an instant. It is meant usually for astrology.

---

70. Cf. G. A., pp. 293 et seq. For various other types of yogas in Jaina astrology, vid. *Jyotiṣasāra*, trans. B. D. Jain, Calcutta, 1923, pp. 40 et seq.

## 6. KINEMATICS OF ASTRAL BODIES

Candraprajñapti's commentaries<sup>71</sup> give for greater details of a Jaina calendar based on calculation of motion of various types of heavenly bodies, especially that of the sun, the moon, and the nakṣatras. Tiloyapaṇṇatti<sup>72</sup> as well as Trilokasāra,<sup>73</sup> Lokavibhāga and Jambūdvīpa prajñapti also relate the concise knowledge of the above.

### NAKṢATRA SYSTEM ABROAD

In Prakrit, Jyotiṣka is written as Jodisiya or Joisiya or Joisia, reminding one, of the word Zodiac<sup>74</sup>. Controversy regarding the relation between the Indian nakṣatra, Arabic al-manāzil, "moon-stations", and the Chinese hsiu systems. The earliest reference outside Asia is in a Greek papyrus of the +4th century. The origin is common, but the question is which is the oldest? Both in China and India, the new year was reckoned from the mansion corresponding to  $\propto$  Virginis, and in both cultures Pleiades was one of the four quadrantal asterisms. Two important statements are, "The *nakshatra* do not show so clearly the 'coupling' arrangement discovered by Biot (4), whereby *hsiu* of greater or lesser equatorial breadth stand opposite each other<sup>f</sup>." "The Chinese has possessed<sup>l</sup>, from fairly early times, a twelvefold division of the year and the equator, which being based upon *hsiu* and palaces, consisted of unequal parts.<sup>g</sup>"<sup>75</sup>

One more statement by Needham and Ling is, "Now in these texts there is never any mention of any zodiac or of constellations lying along the ecliptic; the earliest documentary evidence of this conception occurs<sup>e</sup> just after -420. On the other hand, the Seleucid cuneiform texts of the -3rd and -2nd centuries give great prominence to the Zodiac, and use ecliptic

71. Cf. C. P., comms. by Malayagiri and Amolaka Rṣi. Cf. also, S. P.

2. Cf. T.P., II, ch. VII.

73. Cf. T. S., ch. IV.

74. Compare the lunar Zodiac of China with that of Jaina School. Cf. Needham & Ling, op. cit., pp. 252 et. seq.

75. Cf. ibid, pp. 253, 258.

coordinates exclusively. Finally, the thirty-six Old Babylonian asterisms were confused with the Egyptian decans and twelve of them ousted to make room for the Zodiacal constellations. One might fairly surmise, therefore, that the equatorial moon-stations of East Asia originated from Old Babylonian astronomy before the middle of the -1st millennium and probably a long time before.”<sup>76</sup>

## MATHEMATICAL ASTRONOMY

The authors, it appears, have not gone through the details of the nakṣatra system of Zodiac in the Jaina School. The tables above speak of a great similarity between the Jaina School and the Chinese School and the transmission could be thought possible, both east and west ways, even before the Budhists entered into the lands. The Zodiac of the Jaina School was so predominant that every nakṣatra of the Zodiac had its own sign and Yogatārās.<sup>77</sup>

According to Neugebauer, “Thus magic, number mysticism, astrology are ordinarily considered to be the guiding forces in Babylonian science. As far as mathematics is concerned, these ideas have had to be most drastically revised since the decipherment of mathematical texts in 1929 .....Early Mesopotamian astronomy appeared to be crude and merely qualitative, quite similar to contemporary Egyptian astronomy. At best since

76. Cf. *ibid.*, p. 256.

77. The C. P. mentions, “Gosīsāvali, Kāhāra, Sauṇi, pupfovayāra, vāviya, ṇāvā, āsakkhandhaga, bhaga, churagharāe, ya Sagaduddhī ||1|| miga sisāvali, ruhira bindu, tula, vaddhamāṇa, padāgā, pāgāra, pallaṅke, hatthe. muhuphullae ceva ||2|| Khilaga, dāmiṇi, egtāvali ya gayadenta, vicchuyāṇāṅgūle, ya gayavikkame, ya tatto, sīhanīstiyā, ya sanṭhāṇā. ||3|| p. 312, (10.9 1). The T. P, II mentions variants :

Viyaṇaya sayalauddhī kuraṅga siradivatorāṇāṇam ca ||  
 Ādavavāraṇa vamniya go muttāṇ sarajugāṇam ca || 465 ||  
 Hatthuppaladivāṇam adhiyaraṇam hāravīṇa siṅgā ya ||  
 Vicchuva dukkaya vāvi kesarigayasīsa āyārā || 466 ||  
 Murayam patantapakkhī seṇā gayapuvva avara gattā ya ||  
 ṇāvā hayasira sarisā ṇam cullī kitti yādīṇam || 467 ||

It appears that C. P. belonged to the observations taken in the north and the T. P. observations might have been taken in the south of India, resulting in the difference of signs of the Zodiac.

Cf. T. P. II, vv. 463-464 & C. P., 10. 9. 1, p. 313 for stars of the nakṣatras.

the Assyrian period, a turn towards mathematical description becomes visible and only the last three centuries B. C. furnished us with texts based on a consistent mathematical theory of lunar and planetary motion."<sup>78</sup>

In the above context, it may be remarked that the Jaina School by the early centuries B. C. had already developed a mathematical theory of the motion of heavenly bodies, but, as Yativṛṣabha<sup>79</sup> mentions, by his time, the description of the motion of planets had become extinct. Yet, what remains, in C. P., S. P. or T. P., is enough to prove that they were in possession of a complete calendar based on mathematical theory, which was ingenious and original. The astro-universe of this school is rather a symmetrical mathematical structure, with a set-theoretic base, depicting the details of a non-summable stretch, yet finite in measure. For example, the total number of astral images is the quotient set obtained by dividing the square of the Jagaśreṇī (set of points) by the product of the set of the squared finger width (pratataṅgula), and the square of 256. The distribution of the astral objects is symmetrical and based on the five kinds of Joigaṇa (astral-groups). The moon, the sun, the planet, the constellation (nakṣatra), and scattered stars (prkṛṇaka tāṛās).<sup>80</sup> The moon is the head of the family of eighty-eight planets, twenty-eight nakṣatras, and 66975 (10)<sup>14</sup> stars.<sup>81</sup>

## SYMMETRIC SETTING

*Picture of the Celestial Phenomena* in Jaina School is unusual.

The phenomena of the heavenly events in all the islands could be represented by those in relation to the Jambūdvīpa wherein, a strange theory of real and counter bodies, exists.<sup>82</sup> Upto certain number of islands, the astral bodies are in motion with mathematical symmetry of exact bodies placed on fictitious orbits, as if images at diametrically opposite ends. Beyond these islands and oceans the astral bodies have been assumed at rest.

The Jambū island is one lac yojana in diameter, all the subsequent alternately placed oceans and islands being double the preceding in diameter, forming a geometrical progression with one as the initial term and two as the common ratio. It is quite clear that such a symmetry denotes the manipulation of the causality theory through an abstract, mathematical model, principle theoretic in nature, surviving through consistency.

78. op. cit., p. 97.

79. Cf. T. P., II, 7.457, 7.458.

80. Cf. T. P. II, 7.29, 7.30. Cf. also T. S., 4.361, 4.303.

81. Cf. T. S., 4.362. Cf. also G. A., pp. 257 and 274 et seq.

82. Cf. T. S., 4.308. Cf. also T. P. G., pp. 86-95. Cf. also G. A., p. 253.

In the centre of the Jambū island has been supposed a type of celestial axis, Meru<sup>83</sup> mountain, perfectly symmetrical, having a height of one lac yojana, in the forms of various frustrums of cones, joined at different heights, and having a lowermost base with a diameter of  $10090 \frac{10}{11}$  yojanas, where as the uppermost base has a diameter of 1000 yojanas. That is how, the motion of all astral bodies around it, or placed at rest in far off islands, suggest the idea of a celestial diagram of a complex nature.

## SHADOW PLANETS

Due to the postulation of two suns and two moons along with the families in both parts of their celestial sphere, one in each half, placed at diametrically opposite ends, the mystery resembles that in China, Greece and Bābylon,<sup>84</sup> which has not been explained so far, whether its purpose was some mathematical convenience for calculations of the motion and positions of the invisible bodies in the other half.<sup>85</sup>

In astrological Jaina texts, like the Jñānapradīpikā, there has been use of invisible planets, with different types of orbits, say in Jinendramālā.<sup>86</sup>

- 
83. Cf. T. P. G., vv. 7.1780 et seq. Compare this description with that given by Āryabhaṭa –I. Cf. Jain, L. C., Āryabhaṭa –I and Yativṛṣabha –a Study in Kalpa and Meru, I. J. H. S., vol. 12, no. 2., nov. 1977, pp. 135–146.
84. Needham and Ling remark, “But as we shall see<sup>l</sup>, the Chinese had themselves imagined, from ancient times, the existence of a ‘counter-Jupiter’ which moved round diametrically opposite the planet itself. There was a Greek parallel to this in the strange Pythagorean theory of the ‘counter-earth’, apparently due to Philolaus of Tarentum (late –5th century), which was devised either to bring the number of planets up to a perfect number, 10, or to explain lunar eclipses.<sup>m</sup> Perhaps both originated from a more ancient Babylonian Theory.” Op. cit., p. 228, vol. III.
85. Cf. Jñānapradīpikā, trans. ed. by R. V. Pandeya, Arrah, 1934, vv. 8, 9, pp. 3,4 for invisible planets, named as dhūma, vyatīpāta, pariveṣa, indradhanu and dhvaja.
86. Ed. S. Singh, Bombay, 1958. pp., 2, 3, 4, for setting of opposite rāsīs and planets, cf. pp. 14, 15, 18, 19. The English translation of this text was published at Madras by N. C. Aiyar, as stated by Singh. In both, Jinendramātā and Jñānapradīpikā, astrological consideration has been given to invisible planets, or shadow planets.

Needham and Ling have further opined as follows,<sup>87</sup> "Here Thai Yin is not, as might be supposed, the moon, but an invisible 'counter Jupiter' which moved round in the opposite direction to the planet itself.<sup>c</sup> Jupiter (Sui hsing<sup>2</sup>), with the other planets, appears to move eastwards or anti-clockwise through the stars, so a 'shadow-planet' (Thai sui<sup>3</sup> or Sui Yin<sup>4</sup>) was invented to move with them, accompanying the sun. Wang Chhung, in *The Lun Hêng*, devotes a whole chapter<sup>d</sup> to this peculiar theory.<sup>e</sup> The twelve Jupiter-stations were named *tzhu*<sup>5</sup> and the whole cycle of years a *chi*.<sup>6</sup> The names for the years have survived in two forms, one set astronomical<sup>f</sup> another astrological;<sup>g</sup> and it was natural therefore that they should sometimes also have been used for the months of a single year and<sup>h</sup> for the double hours of a single day, as well as for the years of the Jupiter cycle.<sup>a</sup> The astronomical terms were used to designate the positions of Jupiter, the astrological or calendrical terms applied to the positions of counter-Jupiter. b"<sup>88</sup> If it is possible to trace out the details of planetary motion in some text of Jaina School, it may throw some light as to the source of the above theory. However, from the available data about the planets and Yuga theory, the motion of the Jupiter, alongwith astrological theory in *Jinendramālā* or *Jñānapradīpikā*, the secrets could be unravelled to a great extent.

## MOTION OF ASTRAL BODIES

The whole of the celestial path has been divided into 109800 celestial parts (*Gagaṇa Khaṇḍa*). But half of the path is covered by one sun, one moon, and its family, without any correlation, in twenty-four hours or thirty muhūrtas. The other half path is covered simultaneously, in the opposite sense, in so far as their journeys start from opposite ends. Thus only 54900 parts are needed for practical purposes of a calendar, and now from the above knowledge it appears that the other half might have some other use.

The motion of the astral bodies every muhūrta is given as follows :<sup>89</sup>

The nakṣatras	1835 celestial parts
The sun	1830     ,,     ,,

87. Cf. op. cit., vol. III., pp. 402, 404.

88. Compare this with the nakṣatra saṁvatsara where the Jupiter's twelve year motion is correlated with that of the nakṣatras : Jam vā bahassa mahaggahe duvālasahim saṁvaccharehim savveṁ paḁkhatta maṇḍalam samāṇei || 10.20, C. P., sūtra 2.

89. Cf. T. S., 4.402 and 4.405. The T. P. has not mentioned about rāhu.

The moon	1768 celestial parts
The rāhu	1829 $\frac{11}{12}$ " "

The kinematic motion of the nakṣatras is actually due to the rotation of the earth. Keeping or regarding them as fixed, the relative motion of remaining bodies with respect to the nakṣatras can be found to be 5, 6 7, and  $5 \frac{1}{12}$  celestial parts per muhūrta.

Now the rāhu, as it appears from the Trilokasāra (11th century), is a fictitious body meant for a seasonal or sāyana ṛtu or karma year (samvatsara). By this rāhu,  $\frac{61}{12}$  celestial parts are traversed in  $\frac{1}{30}$  of a solar day, hence the stretch of a zodiacal sign of  $30^\circ$  or 4575 celestial parts is travelled in a month of 30 solar days. Thus 54900 celestial parts are traversed in 360 days or twelve months. This rāhu, thus defines the mean annual motion of the sun, which describes 1830 celestial parts in  $\frac{1}{30}$  of a day or  $360^\circ$  in a day which defines the basic unit, solar day, used in astronomy. The Tattvārthasūtra also describes, "The astral bodies – the sun, the moon, the planets, the constellations and the scattered stars, in the human region (nṛloka), are characterized by incessant motion around Meru, and they cause the divisions of time."<sup>90</sup>

### RELATIVE MOTION OF NAKSATRAS

The daily motion of the nakṣatras is defined as 1835 celestial parts or  $12 \frac{2}{61}$  degrees per muhūrta or 48 minutes. Thus 54900 celestial parts or  $360^\circ$  are covered in  $\frac{1830}{1835}$  part of a day, or 23 hours 56 minutes and  $4 \frac{1060}{1835}$  seconds. Modern value of such a sidereal day is 23 hours 56 minutes 4.1 seconds. Thirty such revolutions make  $29 \frac{1685}{1835}$  days. Three hundred sixty such revolutions make  $359 \frac{35}{1835}$  days. Three hundred sixty-six such revolutions make  $365 \frac{5}{1835}$  days. Relatively this will be regarded as rotation of the earth with respect to a fixed nakṣatra or a star therein, without any proper motion (as the first point of Aries has at the rate of 50."2 per annum).

90. Cf. Reality, op. cit., ch. 4, vv. 12-14,

Now with respect to the nakṣatras, the sun moves 5 celestial parts less per muhūrta. Thus it traverses 150 celestial parts in a day and 54900 parts or  $360^{\circ}$  in 366 days, which is in relation to fixed stars. The average solar month is thus of  $30\frac{1}{2}$  days.

Similarly the moon covers 67 celestial parts less with respect to the nakṣatras, per muhūrta, covering the strip of 54900 celestial parts in  $27\frac{21}{61}$  solar days or 27.313 days, where as the modern value for a lunar side real month is 27.32166 days.

The ṛtu rāhu moves  $1829\frac{11}{12}$  celestial parts per 48 minutes, and describes the strip of 54900 celestial parts in a  $\frac{21060}{22259}$  solar day. Relative to nakṣatras the ṛtu rāhu moves  $\frac{61}{12}$  celestial parts in a muhūrta. Hence it covers the strip of 54900 celestial parts or  $360^{\circ}$  in 360 solar days. This is a ṛtu year. The mean solar day is thus equal to  $\frac{22259}{21060}$ . The modern value of this is 24 hours, 3 minutes, 56.5 seconds. It appears that this rāhu was perhaps responsible for division of year and the strip into twelve equal parts, for it gives 12 stations as well, and consequently led to the invention of 12 rāśis, or 12 zodiacal signs. No where in the history of astronomy, one comes across with such a rāhu as in the Trilokasāra, described above. Here one degree has been set in equivalence with one day,<sup>91</sup> as in China.

The motion of the stars has been mentioned to be greater than that of the nakṣatras, showing that the school was aware of the proper motion

91. For such a description of the sun, Needham and Ling quote, "The uniform and apparently circular rotation of the heavenly bodies is mentioned many times in texts which are probably much older than Chang Hêng or even Lohsia Hung, for example the *Chi Ni Tzu*<sup>4</sup> book<sup>e</sup> and the *Wên Tzu*<sup>5</sup> book. The former (perhaps of —3rd or —4th century) speaks of the sun's path as a turning ring (*hsün huan*<sup>6</sup>) with limits but no starting-point (*wei shih yu chi*<sup>7</sup>) ever rotating (*chou hui*<sup>8</sup>) and never still, the sun moving  $1^{\circ}$  each day. <sup>f</sup> [The extremely early appearance of this graduation system, which led to  $365\frac{1}{4}^{\circ}$  instead of  $360^{\circ}$  in the Chinese circle, should be noted.] Cf. pp. 218, 219.

of stars, although details are not available.<sup>92</sup> The sun, the moon and the moving planets have their solstices (ayanās), but the nakṣatras and the stars have no laws for solstices.<sup>93</sup>

## RELATIVE MOTION OF THE SUN

The motion of the sun is 1830 celestial parts per muhūrta. Thus the full stretch of 54900 parts are described in 30 muhūrtas or 24 hours. This is the mean motion. The ketu, an invisible planet moves along with the sun under it at a depth of four standard fingers below, causing the eclipse at periodic intervals. All the astral bodies are described to move leaving a distance of 1121 yojanas from the celestial axis (Meru) so far as the Jambūdvīpa is concerned.<sup>94</sup>

The solar and lunar zodiac (Cāra kṣetra) has an extension of  $510 \frac{48}{61}$  yojanas.<sup>95</sup> Out of this, 180 yojanas are covered in the Jambūdvīpa by the sun and the moon, whereas the remaining stretch lies in the Lavaṇa ocean.<sup>96</sup> In the Tiloyapaṇṇatti, the description of 15 roads of the moon,

- 
92. Cf. T.P., II, 7.896. The miscellaneous stars are of two kinds; moveable and immoveable. Cf. *ibid.* 7.494. Cf. also *ibid.*, 7.497.
93. Cf. *ibid.*, 7.498 and 7.499.
94. Cf. T. P., II, 7.201, & T. S., 4.345.
95. Needham and Ling remarks regarding Chinese and Babylonian zodiacs are important, "Now in these texts there is never mention of any zodiac or of constellations lying along the ecliptic; the earliest documentary evidence of this conception occurs <sup>a</sup> just after —420. On the other hand, the Seleucid Babylonian cuneiform texts of the —3rd and —2nd centuries give great prominence to the zodiac, and use ecliptic coordinates exclusively. Finally, the thirty-six Old Babylonian asterisms were confused with the Egyptian decans and twelve of them ousted to make room for the zodiacal constellations. One might fairly surmise, therefore, that the equatorial moon-stations of East Asia originated from Old Babylonian astronomy before the middle of the —1st millennium and probably a long time before." Cf. *op. cit.*, III, p. 256.
96. Cf. T. S., 4.374.

and one hundred and eighty-four paths of the sun are described in details of their velocities in Yojanas through the asterisms zodiac (cāra mahī).<sup>97</sup>

The orbits of the sun being 184, there are 183 solar days in a single solstice, implying that its continuous motion is in a winding and unwinding spiral, each of which is at an interval of about 2 yojanas. Every day the total shift in the path is by  $\frac{170}{61}$  yojanas. The first internal orbit of the sun is 315089 yojanas, and the last orbit is about 315106  $\frac{38}{61}$  yojanas in circumference.<sup>98</sup>

It is strange, how the measure of length of day is 18 muhūrtas when the sun is in first internal orbit, and that of night is 12 muhūrtas, if India had its centre of learning at Ujjain or Patliputra<sup>99</sup>. Reverse is the case when the sun is in the last external orbit. Dixit finds that this increase and decrease mentioned in Vedāṅga Jyotiṣa, applies to regions in 34° North latitude of the earth. This place may be near about Kashmir, or Gāndhāra. Mathematically he calculates this to lie between 34°46' and 34°55' of North latitude<sup>100</sup>.

In the Trilokasāra, one finds the mention of Karkaṣa (cancer) and makara (capricornus). The motion of the sun in the next spiral orbit is

97. Cf. T. P., II, 7.117 to 7.271. The description of the length of day and night as well as that of bright and dark areas for different roads is given from vv. 7.276 to 7.455.

98. Cf. T. P., II, vv. 7.254 to 7.263. Cf. also T. S., 4.378.

99. Cf. T. S., 4.379 and T. P. II, 7.277. In the Babylonian and Egyptian scheme, Neugebauer describes the length & its variation on pp. 116, 159 and 86, 94. However, for India he opines, "This was fully in line with a discovery which had been made by Kugler in 1900, namely, that the ratio 3:2 of longest to shortest day used by both systems in columns C and D of the Babylonian lunar ephemerides also appears in Hindu astronomy, though this ratio is totally incorrect for the main parts of India." Cf. op. cit., p. 162. Cf. also D. Pingree, (1974) Mesopotamian Origin of Ancient Indian Mathematical Astronomy, I. H. A., IV, pp. 1-12.

100. Cf. op. cit., pp. 125, 126, 131. Cf. also Sharma, S. D., and Lishk, S. S., "Length of the Day in Jaina Astronomy," Centaurus 22.3, Andelsbogtrykheriet.

either accelerated or retarded, rather the sun is in retarded motion every instant while moving out, and is in accelerated motion every instant while moving towards inner side. 101 This also signifies the Kinematic motion for covering of unequal distances in equal time for a mean solar day. The ranges of vision and the rise stations also find place in these texts. The calendrical details of the ayanas, parvas, tithis, viṣupas have been given in great details, along with charts in the Candraprajñāpti in dialogue style. 102

## RELATIVE MOTION OF THE MOON

Kinematically, all the astral bodies have been regarded hemispherical, with spherical side towards the earth, the diameter of the moon being  $\frac{56}{61}$  yojanas and that of the sun being  $\frac{48}{61}$  yojanas. 103

Two types of rāhus are described for the moon, dina rāhu and parva rāhu. The former causes the phases of the moon, the latter causes lunar eclipses. 104

Regarding the relative motion of the moon with respect to the nakṣatras, the moon travels 67 celestial parts, kinematically less, than those traversed by the nakṣatras, covering the strip of 54900 celestial parts in  $27 \frac{21}{67}$  solar days or 27.313 days, the modern value for the lunar sidereal month being 27.32166 days. The relative motion of the moon with respect

- 
101. Cf. T. S., 4.380. Cf. Needham and Ling, p. 292 for Chinese discovery of tropic of cancer in + 349. Cf. also T. S., 4.381 to 4.386. Cf. T. P., II, 7.291 to 7.420 for bright and dark areas. For acceleration etc., cf. *ibid.*, 7.265, and T. S., 4.388. According to Chou Pei, the sun could illuminate an area only 167000 li in diameter; people outside this would be said to be in dark. Cf. Needham and Ling, p. 211. The Jaina School, due to its discoidal maps, gave these areas projected on a plane.
102. Cf. C. P., T. P. and T. S. at proper places.
103. Cf. T. P. 7.37, 7.218, 7.39, 7.68, 7.91, 7.95, 7.98, 7.100 and 7.108 for planets and constellations as well. In China only the sun's diameter is described. Cf. Needham & Ling, pp. 300, 332, 573 (c). Similarly no record is available in Babylon, Egypt and Greece.
104. Cf. C. P., pp. 693-702; T. S., 4.340, 4.342, T. P., 7.202, and 7.205 to 7.216. Cf. also G. A., pp. 279-288. For Chinese conception, cf. Needham and Ling, pp. 175, 228, 252 (c), 416, where the idea of monster and colours appears to be imported from India, or a work from the west, "Kicou-tche."

to the sun being 62 celestial parts in  $\frac{1}{30}$  th day, it covers the stretch of 54900 celestial parts in  $29 \frac{32}{62}$  or 29·516 days, where as the modern value for lunar synodic month is 29·5305 days. This is the data for a mean motion of the moon. 105

The motion of the  $\text{ṛtu rāhu}$  with respect to the moon is  $\frac{743}{12}$  celestial parts less in a  $\text{muhūrta}$ , hence the moon covers 54900 celestial parts ahead of it in  $29 \frac{413}{743}$  or 29·555 days, which represents lunar fictitious synodic month. The mean of true and fictitious being 29·535, it differs from modern value by ·005 only. 106

The motion of the moon is also in spiral orbits, its zodiac being the stretch of  $\frac{31158}{61}$  yojanas. The roads or the orbits of the moon are defined to be 15, with an interval of  $35 \frac{214}{427}$  yojanas each, in the  $\text{Jambūdvīpa}$  and  $\text{Lavaṇasamudra}$ . 107 The motion of the moon in yojanas per  $\text{muhūrta}$  for different paths is detailed. 108 This is a very important record in linear

105. Cf. T. P., 7-508. Cf. Neugebauer, pp. 118, 121, 162 and Needham and Ling, pp. 392-401, vol. III.

106. Cf. T. S., 4.402 and 4.405. For comparison with Babylonian lunar velocity, cf. Neugebauer, pp. 118, 119, 121, the mean velocity being 13; 10.35<sup>0</sup> per day. The mean synodic month was close to 29, 31, 54 days. Cf. *ibid.*, p. 122.

107. Cf. T. P., II, 7-125, 7-120 & T. S., 4-396, 4-377. The eccentric circle theory of sun's motion was recognized in China after about +570. Akin to three types of  $\text{nakṣatres}$  in Jaina School, in China, the planispheres consisted of 'three roads' each marked with twelve stars, one for each of the months corresponding to their heliacal risings. The central road was called Anu, the outer road as Ea, and inner road as Enlil. Cf. Needham and Ling, vol. III, p. 256.

108. Cf. T. P. 7-186 to 7-200. These details are not available in T. S., nor in C. P.

measure. Its path is also given through various nakṣatras, along eight paths. 109

The motion of planets is not available in the records of practically all the ancient Jaina texts. Only Thāṇāṅga ( g. 699) mentions nine orbits of the venus. Samvāyāṅga (19.3) states that the venus, rising in the west, moving through nineteen nakṣatras, sets in the west alone.

---

109. Cf. T. P., 7·460-462. For Chinese system, cf. Needham and Ling, p. 225. Cf. also Neugebauer, pp. 5, 81, 82, 89, 116 (India), 102, 140, 170, 180, 207. In the Tiloypanṇatti, details of stars & symbols for their collection are given in 7·463-467. The names of eighty-eight planets are available. Cf. T. P., II, 7·363-370, and so on.

## 7. RATIONALIZATION OF YOJANA

### 1. CHINESE LI

The word *yojana* appears in every earlier Jaina text. It has been used either for denoting areal distances as velocities of heavenly bodies, or as distances as straight lines on a plane surface. It has also been used to denote heights. It seems to have been derived from the word *Yojanā*, meaning something like a pattern or some principle of organization. In China a parallel word, though not exactly *Yojana*, carrying a similar meaning got evolved in Neo-Confucian<sup>110</sup> thought, “The induction of a specific principle from many observations ( *b*’, the second part of *resolutio*) was represented in Neo-Confucian thought by the search for the underlying or intrinsic patterns (*li*<sup>1</sup>). Some one said to Hsü Hêng<sup>2</sup> (+1209 to +1281):

If we fully apprehend (lit. exhaust) the patterns of the things of the world, will it not be found that every thing must have a reason why it is as it is ( *so i jan chih ku*<sup>3</sup>) ? And also a rule (of co-existence with all other things)<sup>4</sup> to which it cannot but conform ( *so i tang jan chih tsè*<sup>4</sup>) ? Is not this just what is meant by Pattern (*li*<sup>1</sup>) ?<sup>d</sup>

Hsü Hêng agreed, saying that this brought out very well the meanings of the technical terms employed. All the spatio-temporal relations of all organisms and events in the universe were determined by the ubiquitous manifestations of *li*. ‘Wherever there is *li*’, said Chhêng I-Chhuan<sup>5</sup> (+1033 to +1108), ‘east is east and west is west.’<sup>e</sup>”

For calculation of cosmic distances, extended pattern-principle ( *thui li*<sup>4</sup>) appears to have been applied.<sup>111</sup> Patterns had the aspects from within and outside.

---

110. Cf. Needham and Ling, vol. III, p. 163.

111. Cf. *ibid.* p. 164, 165. This word ‘*thui*’ goes back to Mohists, constantly found in scientific contexts. If the pattern was fully apprehended in one matter only, inferences could be drawn about other matters of the same class.

## 2. TYPES OF ANGULAS

In the Jaina School, or even elsewhere, a yojana is equivalent to 768000 aṅgulas.<sup>112</sup> But, it is only in this school that yojana depends on three patterns of aṅgula which are used for measuring different types of objects. The three different kinds of the aṅgulas<sup>113</sup>; ātmāṅgula, utsedhāṅgula, and pramāṇāṅgula. The Śvetāmbara School takes 1000 utsedha aṅgulas equal to one pramāṇa aṅgula whereas the Digambara School mentions 500 utsedha aṅgula as equivalent to one pramāṇāṅgula. The Buddhist 1 aṅguli-parva is equal to 2 aṅgulas of the Jainas. According to this correspondence a yojana is equal to 8 miles, and the corresponding Śvetāmbara pramāṇa yojana is equal to 8000 miles, but the Digambara pramāṇa yojana is equal to 4000 miles.

The utsedhāṅgula is accomplished by definition and called a sūcyaṅgula (linear finger width). This is used to measure the heights of subhuman, and hellish bodies, as well as the residence and cities etc. of four types of gods. Pramāṇāṅgula is used to measure the regions, the islands, oceans, mountains, altars, rivers, ponds and tanks etc. The ātmāṅgula depends upon the region and time and the human beings corresponding to them, and is used to enumerate ornamental objects (jhāri, kalaśa, darpaṇa, etc.) as well as gardens, cities and residence ch. of human beings.<sup>114</sup>

## 3. EVOLUTION OF YOJANA

Yojana appears in Sūryasiddhānta, and is used for class-measures of the planets etc.<sup>115</sup> Dixit opines that according to vācaspati and Śabdārṇava kośas, a yojana may be taken to be 16000 hands or 5 miles. The Chinese traveller Hiven-Thsang found out that a yojana, equivalent to 30 li could be equal to 6·12 miles. He also mentioned a yojana equal to 40

---

112. A very illustrative article on "The Evolution of Measures in Jaina Astronomy" by Lishk and Sharma in, Tirthaṅkara vol 1 nos. 7-12, 1975, 73-92, may be seen.

113. Cf. G. A., T. P. II, T. S. A comparative study has been given by Muni Mahendra Kumar, II, pp. 233, et. seq.

114. Cf. T. P., II, 7-107-113. For details of the Śvetāmbara school, cf. G. A., pp. 448, 449, 450.

115. Cf. Dixit, p. 420. According to him, in many texts, a yojana is equal to 32000 hands. Taking a hand equal to 19·8 inches, a yojana is 10 miles which comes in contradiction to diameter of the earth. According to Megasthenes (-302 to -293) a yojana was equal to 96000 aṅgulas.

and 16 *H* amounting to  $8 \frac{1}{6}$  or  $3 \frac{1}{3}$  miles. 116

Fleet estimated the value of *yojana* to be  $9 \frac{1}{11}$  *yojanas*. Cunningham, after collating several variations, concludes that a *yojana* is equivalent to 6.7 miles, and Lishk and Sharma have also accepted this value from various considerations that follow. 117

#### 4. RATIONALIZATION

Rationalization of the various data given in Jaina texts has been attempted by the above authors. For example the heights of various planetary bodies and the sun etc. from an unknown region,<sup>118</sup> *uparima tala* (upper surface) of the *Citra* earth, are as follows : 119

The stars	790 Yojanas to 900 Yojanas
The sun	800 Yojanas
The moon	880 „
The nakṣatras	884 „
The Mercury	888 „
The Venus	891 „
The Jupiter	894 „
The Mars	897 „
The Saturn	900 „

Now the measures given about for the sun, the moon etc. immediately appear to contradict the modern view, as well as the date of diameter of them given in Jaina texts, (Sun  $\frac{48}{61}$  and moon  $\frac{56}{61}$  *yojanas*}. Similarly, the distance between the innermost orbit and outermost orbit of the sun is 510 *yojanas*. Lishk and Sharma propose to regard this as arcual distance or roughly 48° of arc, 1° being equivalent to 69.9 miles on the earth's sphere.

116. Cf. *ibid.*, pp. 423, 424. D. A. Somayaji derives a *yojana* as approximating to 5 miles. L. G. Jain has derived in TPG, a value equivalent to that of Fleet. Cf. Lishk and Sharma *op. cit.*

117. Cf. Lishk and Sharma, *op. cit.*, "The Evolution.....,"

118. Śvetāmbara School, S. P. and C. P., regard this region as the extremely plane-beautiful earth-part of *ratna-prabhā* earth.

119. Cf. T. P., II, vv. 7.36, 7.65, 7.82, 7.83, 7.89, 7.93, 7.99, 7.104, 7.108 7.112, Cf. also G. A., pp. 257, 259.

510 yojanas = 48 × 69.9 miles, thus

1 yojana = 6.6 miles roughly.

## HEIGHT AS LATITUDE

Accordingly the height 800 yojanas of the sun, converted into degrees by the same scale becomes  $\frac{800 \times 6.7}{69.9} = 77.5^\circ$ . Sharma and Lishk regard this as the region of the projected ecliptic round the north pole (Meru directed point), also called the plane earth Citrā.<sup>120</sup> If this is the north polar distance of the sun, naturally, the moon at 880 yojanas shall mean, 80 yojanas towards the south of the sun, or below it in celestial diagram. According to the same scale, as suggested above, the maximum north polar distance of the moon from the sun or ecliptic is proposed to be  $\frac{80 \times 6.7}{69.9} = 7.7^\circ$ , the modern value being  $5^\circ 8' 40''$ , to which may approximate the former if a yojana is taken to be 5 miles.<sup>121</sup>

In the same way, the belt from 790 yojanas to 900 yojanas, or 110 yojanas becomes  $\frac{110 \times 6.7}{69.9} = 10.6^\circ$ , a modern value of the lunar zodiac.<sup>122</sup>

Thus the recognition of the heights of the heavenly bodies above the Citra, by Sharma and Lishk, though at present controversial, is praiseworthy and creditable. They proceed on to recognize a correspondence between two patterns of yojanas :

$$800 Y = 50000 y,$$

where Y is in the Tiloyapaṇṇatti units, and radius of the Jambūdvīpa is 50000 y. On this basis they have derived the obliquity of the ecliptic ( $23^\circ.5$ ), in structure of the mathematical model of Meru.<sup>123</sup>

---

120 Cf. "Latitude of the moon as determined in Jaina Astronomy", Śramaṇa, vol. 27, no. 2, pp. 28-35. Cf. also Lishk, S. S., and Sharma, S. D., Notion of circular flat earth in Jaina Cosmography, The Jaina Antiquary, vol. xxviii, no. 1-2, July 1976, pp. 1-5.

121 This easily leads to the concept of celestial latitude which are measured north or south of the ecliptic, from  $0^\circ$  to  $90^\circ$ .

122 Cf. Neugebauer, pp. 102, 103; 82, 89 and 166, 186, for various civilizations. Cf also Needham and Ling, p. 173.

123 Cf. Lishk, S. S. and Sharma, S. D., Notion of obliquity of ecliptic implied in concept of Mount Meru in Jambūdvīpaprajñapti, Jain Journal, Calcutta, Jan. 1978, 79-92.

A peculiarity of the school of Āryabhaṭa is their assertion of measure of the great circle on the celestial sphere as 12,474,720,576,000 yojanas, which is the distance moved by the sun, the moon, or star and planets in a yuga (aeon). According to Lishk and Sharma, the origin of this tradition may be traced back to the Jaina's practice of measuring celestial distances in terms of corresponding distances as projected over the earth.<sup>124</sup>

---

124 "Role of Pre-Aryabhaṭa Jaina School of Astronomy in the Development of Siddhāntic Astronomy," I. J. H. S., vol. 12, no. 2, Nov. 1977, pp. 106-113.

## 8. CALENDRIAL YUGA SYSTEM

The quinquennial yuga or cycle was prevalent in various schools of India, as it was in Jaina school. But, it began with Abhijit. In a cycle of five years there are 60 solar months, 61 ṛtu months, 62 lunar months, 67 nakṣatra months and  $57 \frac{3}{13}$  intercalary months. Now one solar year is of 366 days, one ṛtu year is of 360 days, one lunar year is of  $354 \frac{12}{62}$  days, one nakṣatra year is of  $327 \frac{51}{67}$  days and one intercalary lunar year is of 383 days  $21 \frac{18}{62}$  muhūrtas. Thus all these years will simultaneously begin and close once in a cycle of 156 cycles of 5 years each, because  $156 \times 5$  years will make 780 solar years, 793 ṛtu years, 806 lunar years, 871 nakṣatra years and 744 intercalary lunar years.<sup>125</sup>

Thus the yuga of 285480 days corresponds with the cycles of the following years :

$$\begin{aligned} 366 \times 780 &= 285480 && \text{solar} \\ 360 \times 793 &= 285480 && \text{ṛtu} \end{aligned}$$

125 The equivalence is clear from the following products

$366 \times 60 = 21960$ $360 \times 61 = 21960$ $354 \frac{12}{62} \times 62 = 21960$ $327 \frac{51}{67} \times 67 = 21960$ $\left\{ \begin{array}{l} 383 \text{ days } 21 \frac{18}{62} \text{ muhūrtas} \\ \times 57 \frac{3}{13} \end{array} \right\} = 21960$	$60 \times \frac{156}{12} = 780 \text{ solar years}$ $61 \times \frac{156}{12} = 793 \text{ ṛtu years}$ $62 \times \frac{156}{12} = 806 \text{ lunar years}$ $67 \times \frac{156}{12} = 871 \text{ nakṣatra years}$ $57 \frac{3}{13} \times \frac{156}{12} = 744 \text{ intercalary lunar years}$
---	--

$$354 \frac{12}{62} \times 806 = 285480 \quad \text{lunar}$$

$$327 \frac{51}{77} \times 871 = 285480 \quad \text{nakṣatra}$$

$$383 \text{ days } 21 \frac{18}{62} \text{ muhūrtas} \times 744 = 285480 \quad \text{intercalary lunar.}$$

In a yuga, half the stretch of the full circle, 54900 celestial parts are covered 1768 times by the moon, 1830 times by the sun, and 1835 times by the nakṣatras.<sup>126</sup>

Similarly many problems regarding seasons, parvas, tithis, motion, solstices, equinoxes, avam rātris, and so on, have been solved in full details in the Candraprajñapti, for the whole yuga of five years which are of various types.

-----

---

126 *Rationale* : 1 yuga = 1830 days = 54900 muhūrtas. Now in one muhūrta, the moon moves 1768 c. p., therefore in 54900 muhūrtas, it moves  $54900 \times 1768 = 97063200$  celestial parts.

These divided by half the stretch, i. e. 54900 celestial parts, give set of 1768 half-stretches.

## 9. ASTRONOMICAL THEORY

### 1. Introduction

Albert Einstein, in an article, distinguished between various types of theories in physics<sup>127</sup>. Some of these theories could be specified as principle theories and other could be recognized as constructive theories. The physical theories of astronomy also fall under this demarcation.

#### PRINCIPLE THEORIES

The principle theories employ the analytic method. Their basic elements are not constructed hypothetically ab initio. They are rather empirically discovered. The basic concepts and principles form general characteristic of natural processes. They give rise to mathematically formulated criteria which is required to be satisfied by the separate processes or their theoretical representations. These theories are logically perfect and have a secured foundation. However, if a single principle fails or if a single inconsistency arises, the whole structure has to be remodelled because, then it is next to impossible to retain its originality. Thus the principles herein are required to be powerfully supported by experience and should be reconcilable logically.

#### CONSTRUCTIVE THEORIES

The constructive theories, on the other hand, follow the synthetic method. One has to try to find out a simple and formal scheme to construct a representation of more complex phenomena. If it is possible to understand a group of natural phenomena, through this, it may be regarded as the success of the constructive theory. These theories could be made complete, clear and adaptable, and could be subjected to remodelling without shattering the complete edifice.

---

127 Vid. "What is the Theory of Relativity ?", from Ideas and Opinions, London, 1956, 227-232.

## 2. WHAT IS JAINA THEORY ?

One has thus to see to what class the Jaina astronomical theory belongs? In what way the analytical method adopted in developing the principles of the theory, and to what extent they are mathematically formulated? The abstraction method takes us on one side to the Samaya and Pradeśa, which are both regarded indivisible as the ultimate particle Paramāṇu is indivisible. On the other side, there is the Rajju and the periods like the Pudgala or Bhāva parāvartana. Then they reach the infinities in time and space, through unending periodic phenomena.

We find several instances, when the actual figures are projected, deformed, stretched and yet hold on the invariance for their measure, Then one has to see how much perfect these theories had been made through the application of logic like the Syādvāda, and Anekānta. There is no doubt that whenever a path is needed, and is necessitated, the intellect and intuition find their own way of abstracting out strange and unusual methods like the method of exhaustion, real and counter replacements, setting up of a new system of observation through a new frame, and assimilating all the past known procedures.

It appears that when the Jaina principle theory began to disappoint the scholars in getting consistent results of the natural processes, it was replaced by the constructive theories evolved all the world over.<sup>128</sup> One has to mark out where the differences in measures of observation and calendar arose, in time reckoning at specified places. This naturally led to wrong prediction of the time of eclipses which had been a part of religious observation.

## 3. ECLIPSE THEORY

In the history of astronomy, Thales (c.-585), known for his maxim, "Know thyself," was the first to predict a solar eclipse. It is presumed that he made use of the Babylonian saros period of 223 lunations. Vedic cycle was noted to be of 675 lunations based on recurrence of eclipses in three different colours (black, red and white). Lishk has however observed from Sūryaprajñāpti (v. 105) that the five colours of Rāhu (black, blue, red, yellow and white) yield a cycle of 336 eclipse years. But it is seriously felt that as the Jaina school had framed an astronomical theory, even the phenomena of eclipses could not have escaped their calculations, through the strange and mysterious setting of real and counter bodies. Although they could make correction in the precessional data, yet their

---

128 Cf. T. S. Kupanna Shastri, op. cit. (19).

neglect in the precision of the motion of the sun against the background of stars led them to inconsistent and incompatible results, in course of time. They took 1830 days in their yuga of five years whereas it ought to have been 1826.2819 civil days, leading to a deficit of about a tithi in course of five years.<sup>129</sup> From Gaṇitānuyoga, pp. 303–305, the hours passed after 365 th day of the year is 5.81 hours, when the next year starts.

#### 4. EVOLUTION OF EPICYCLES

The motion of the moon or the sun as described in Parkrit texts comprises of two motions : the rotation of the earth, which in turn, relatively gives a kinematic view of them; the other is their motion along the fixed stars. Both these, unified as one, were manipulated by the ancient school, through motion in circles for each day, with a constant radius, varying from day to day. Actually, due to the continuity of the motion, the geometrical figure of the path comes out to be an spiro-elliptic one, winding and unwinding. Its equation may be written in the form  $r = \frac{f + g\theta}{h+k \cos \theta}$ , where  $r$  is the radial distance of the sun from the earth,  $\theta$  is the angle through which it turns and  $f, g, h$  are constants. The dynamical laws found from the above are those of Newton, Einstein and one more, of attraction.<sup>130</sup>

It is not known exactly, how this system further contributed or did not contribute to the development of the theory of eccentric and epicycles in Greece. If the Greek came to know about independent rotation of the earth, they must have tried to analyse the motion in two parts or through two types of circles. Or, if they wanted to trace the spiro-elliptic path through two circles, they must have planned to trace the path which had approximated simply as a circle for the specific day. As their geometry had become perfect by that time, it was not difficult for them to analyse the unified motion into two parts. Such attempts could also not be denied for India, but the records appear to start from the period of Āryabhaṭa-I. Yet the yuga system was given, perhaps a priority, in which again, there were cycles, of periodic character, based on the following siddhāntas; as found by A. N. Singh,<sup>131</sup>

129 Cf. Dixit, *op. cit.*, pp. 129–131. Cf. also, Petri, W., *op. cit.*, for colours of lunar eclipses.

130 Cf. Jain, L. C., [17], *op. cit.*

131 Cf. Radhakrishnan, S., *op. cit.*, article by Singh on Mathematics and Astronomy, pp. 444 et seq., in *History of Philosophy, Eastern and Western*, London, 1957.

- (a) Every astronomical phenomena recurs after a fixed period.
- (b) In the beginning of creation and each yuga, all the planets were in one line, i, e, at zero longitude.
- (c) All heavenly bodies have equal linear motion.
- (d) The rates of their angular motions are different.
- (e) Motion of planets is irregular because they are attracted towards moving points in the heavens.
- (f) Earth is spherical like an iron ball surrounded by magnets.

It has to be seen whether this was a constructive theory.

## (A) BIBLIOGRAPHY OF SOURCE MATERIAL

- 1 ] Gaṇitānuyoga, compiler Muni Kanhaiyalal, Kamal, trans. M. L. Mehta, ed. S. Bharilla, Sanderao, 1970.
- 2 ] Reality, Eng. Trans. of Pūjyapāds' Sarvārthasiddhi commentary (of Tattvārthasūtra), S. A. Jain, Calcutta, 1960.
- 3 ] Pañcāstikāya of Kundakunda, trans. Prof. Chakraverty, Arrah, 1920.
- 4 ] Lokavibhāga, Simhasūri, Sholapur, 1962.
- 5 ] Tiloyapaṇṇatti of Yativṛṣabha, Parts I & II, Sholapur, 1943, 1952.
- 6 ] Jambūdvīpa paṇṇatti of Padmanandi, Sholapur, 1958.
- 7 ] Jyotiṣakaraṇḍaka, (comm. by Malayagiri), Ratlam, 1928.
- 8 ] Lokaprakāśa, I, II, Surat, 1932, III, Bhavanagar, 1934.
- 9 ] Jambūdvīpa paṇṇatti sūtra, Sikandarabad.
- 10 ] Tḥāṇāṅga sūtra, Ahmedabad, 1937.
- 11 ] Trilokasāra of Nemi Chandra, Bombay, 1911.
- 12 ] Bḥhadravyasaṃgraha of Nemicandra, Bombay, 1906.
- 13 ] Candraprajñapti sūtra, trans. Shri Amolaka Rṣi, Sikandarabad.
- 14 ] Dhavalā commentary of Ṣaṭkhandāgama, book 4, Amaraoti, 1942.
- 15 ] Gommaṣasāra Jivakāṇḍa, Nemicandra, J. L. Jaini, Bombay, 1927.
- 16 ] Sūryaprajñapti, Hindi trans. by Amolaka Rṣi, Sikandarabad (Virābda 2445); Comm. by Malayagiri, 1919, Sahesana.
- 17 ] Jivabhigama Sūtra.
- 18 ] Bhagavati Sūtra, trans. Amolaka Rṣi, Sikandarabad also, Bombay, 1918, also com. by Abhayadeva Sūri, Ratnapuri, 1937.
- 19 ] 'Ārṣa Jyotiṣa,' Dvivedi, S., Benaras, 1906. 'Atharva [ Vedāṅga Jyotiṣa ] Jyotiṣa', Datta, Bhagvad, Lahore, 1924.

- 20 ] Yantrarāja, Mahendra Sūri, Bombay, 1936.
- 21 ] Rana Sañcayaprakaraṇa.
- 22 ] Jñānapradīpikā, trans. Pandeya, R. V., Arrah, 1934. .
- 23 ] Jinendramālā, ed. & trans. Singh, S., Bombay 1958.
- 24 ] Jambudvīpasamās of Umāsvāti, ed. Vijaya Siṃha Sūri, Ahmedabad, 1922.

## (B) BIBLIOGRAPHY OF SOME RESEARCH MATERIAL

- 1 ] Agrawal, M. B., Gaṇita evam Jyotiṣa ke Vikāsa meṃ Jainācāryon kā Yogadāna, (Hindi), Thesis, Agra University, 1972. pp. 377.
- 2 ] Billard, R., Āryabhaṭa and Indian Astronomy, I. J. H. S., vol. 12, no. 2, Nov. 1977, 207-224.
- 3 ] Billard, R., L'astronomie indienne, investigation des textes sanskrits et des données numériques, Paris, Arien-Maisonneuve, 1971, 181 p.
- 4 ] Das, S. K., The Jaina School of Astronomy, I. H. Q., 8, 1934, 30-42.
- 5 ] Das, S. K., The Jaina Calendar, The Jaina Antiquary, 3.2, Sep. 1937, 31-36.
- 6 ] Gupta, R. C., Circumference of the Jambūdvīpa in Jaina Cosmography, vol. 10, no. 1, 1975, 38-46.
- 7 ] Jaina, L. C., Tiloyapaṅṅatti kā Gaṇita, intr. to Jambūdvīpa prajñapti saṃgraha, Sholapur, 1958, 1-109.
- 8 ] Jain, L. C., Kinematics of the Sun and the Moon in Tiloyapaṅṅatti, Tulsi Prajñā, J. V. B., Ladnun, Feb.-Mar. (1975), 60-67.
- 9 ] Jain, L. C., Jaina School of Mathematics (A study in Chinese Influences and Transmissions), in "Contribution of Jainism to Indian Culture," ed. R. C. Dvivedi, Varansi, (1975), 206-220.
- 10 ] Jain, L. C., The Kinematic Motion of astral real and counter bodies in Trilokasāra, Calcutta, I. J. H. S., vol. II, no. 1, 1976, 58-74.
- 11 ] Jain, L. C., Principle of Relativity in Jaina School of Mathematics, Tulsi Prajna, J. V. B., Ladnun, 5, (1976), 20-28.
- 12 ] Jain, L. C., Āryabhaṭa the Astronomer and Yativṛṣabha, the cosmographer, Tirthankar, vol. 1, nos. 7-12, 1975, 102-106.
- 13 ] Jain, L. C., Certain Physical Theories in Hindu Astronomy, Prachya Pratibha, vol. 5, no. 1, Jan. 1977, 75-86.

- 14 ] Jain, L. C., *Āryabhaṭa-I and Yativṛṣabha —A Study in Kalpa and Meru*, I. J. H. S., vol. 12, no. 2, 1977, 135-149.
- 15 ] Jain, L. C., *On the Contributions, Transmissions. and Influences of the Jaina School of Mathematical Sciences*. Tulsi Prajna, J. V. B., Ladnun, vol. 3, no. 4, 1977, 121-134.
- 16 ] Jain, L. C., *Distinct Features of Indian Astronomy upto Āryabhaṭa-I*, Prachya Pratibha, vol. 4. no. 2, July 1975, 118-123.
- 17 ] Jain, L. C., *On spiro-elliptic Motion of the Sun implicit in the Tiloyapaṇṇatti*, I. J. H. S., vol. 13, no. 1, 1978, 42-49.
- 18 ] Joshi, S. C., *Nicolaus Copernicus and the Commentariolus* I. J. H. S., vol. 9, no. 1, May 1974, 25-30.
- 19 ] Kupannashastri, T. S., *The School of Āryabhaṭa and the Peculiarities thereof*, I. J. H. S., vol. 4, nos. 1-2, 1969, 126-134. Cf. also "A historical Development of certain Hindu astronomical Processes," in the same volume.
- 20 ] Kuchment, M. M., ( S. S. S. R. )-Cosmology of Newton, Proc. of XIII Int Cong. of Hist. of Sc., Moscow, 1971, 223-225.
- 21 ] Lishk, S. S. and Sharma, S. D., *Post-Vedāṅga Pre Siddhāntic Indian Astronomy*, Paper read at I. N. S. A., New Delhi, 1974 ( Summer School ), 233-1-16.
- 22 ] Lishk, S. S. and Sharma, S. D., *The Evolution of Measures in Jaina Astronomy*, Tirthankar, 1 (7-12), 1975, 83-92.
- 23 ] Lishk, S. S. and Sharma, S. D., *Occultations of the Moon in Jaina Astronomy*, Tulsi Prajna, 3, 1975, 64-69.
- 24 ] Lishk, S. S. and Sharma, S. D., *Chatrātichatra Yoga in Sūrya-prajñapti*, Tirthaṅkar, vol. 2, no. 1, Mar. 1976, 27-35 & 41.
- 25 ] Lishk, S. S. and Sharma, S. D., *Notion of circular flat Earth in Jaina Cosmography*, The Jaina Antiquary, vol. XXVIII, Jul. 1976, No. 1, 2; 1-5.
- 26 ] Lishk, S. S. and Sharma, S. D., *Sources of Jaina Astronomy in Jaina Canonical Literature*, The Jaina Antiquary, vol. 29, no. 1-2, 1976, 19-32.
- 27 ] Lishk, S. S. and Sharma, S. D., *Notion of Obliquity of Ecliptic implied in the Concept of Mount Meru in Jambūdvīpaprajñapti*, Jain Journal, Calcutta, Jan. 1978, 79-92.

- 28 ] Lishk, S. S. and Sharma, S. D., Role of pre-Āryabhaṭa Jaina School of Astronomy in the Development of Siddhāntic Astronomy, I. J. H. S., vol. 12, no. 2, Nov. 1977, 106-113.
- 29 ] Lishk, S. S., and Sharma, S. D., Season Determination through the Science of Sciatherics in Jaina School of Astronomy, I. J. H. S., vol. 12, no. 1, May 1977, 33-44.
- 30 ] Nahata, A. C., Jaina Jyotiṣa aurā Vaidyaka Grantha, Shri Jaina Siddhānta Bhāskara, Arrah, vol. 4, no. 2, 1937, 110-118.
- 31 ] Neugebauer, O., The Equivalence of eccentric and epicyclic Motion according to Apollonius, Scripta Mathematica, vol. 24, 1959, 5-21.
- 32 ] Pande, M. C., Pre-copernican Astronomy in Europe, I. J. H. S., vol. 9, no. 1, 1974, 123-137.
- 33 ] Petri, W., Colours of Lunar Eclipses according to Indian Tradition, I. J. H. S., vol. 3, no. 2, 1968, 91-98.
- 34 ] Pingree, D., Mesopotamian Origin of ancient Indian Mathematical Astronomy, J. H. A., IV, 1974, 1-12.
- 35 ] Saraswati, T. A., The Mathematics in the first four Mahādhikāras of the Trilokaprajñapti, Jour. Gang. Res. Inst., 18 (1961-62), 27-51.
- 36 ] Sen, S. N., Epicyclic-eccentric planetary theories in ancient and medieval Indian Astronomy, I. J. H. S., vol. 9, no. 1, 1974, 107-121.
- 37 ] Sharma, S. D. and Lishk, S. S., Latitude of the Moon as determined in Jaina Astronomy, Śramaṇa, vol. 27, no. 2, Dec. 1975, 28-35 (Varansi).
- 38 ] Sharma, S. D. and Lishk, S. S., Length of the Day in Jaina Astronomy, Centaurus, 22 : 3, Andelsbogtrykheriet.
- 39 ] Shastri, N. C., Jaina Jyotiṣa Sāhitya, Acharya Bhikshu Smṛiti Grantha, Calcutta, Sec. ii (1961), 210-221.
- 40 ] Shastri, N. C., Gṛīka-pūrva Jaina-Jyotiṣa Vicārādhārā, Br. Chanda bai Abhinandan Granth, Arrah, 1954, 462-466.
- 41 ] Shastri, N. C., Bhārtīya Jyotiṣa kā poṣaka Jaina-Jyotiṣa, Varni Abhinandan Granth, Saugar, 1962, 478-484.
- 42 ] Shastri, N. C., Jaina Pañcāṅga, Shri Jaina Siddhanta Bhaskar, 8.2, Dec. 1941, 74-80.

- 43 ] Shea, W. R., Gorge Locher's "Disquisitiones mathematicae de controversiis et novitatibus astronomicis" and Galileo's "Dialogue on the two world systems," Proc. of XIIIth Int. Cong. of Hist. of Sc. Moscow, 1971, 211-218.
- 44 ] Shukla, K. S., Astronomy in India before Āryabhaṭa-I, paper read at silver jub. cele. of B. G. P., Lucknow, 24-10-76, pp. 1-11. Cf. also Jha, P., Āryabhaṭa I : His School, Jour. of the Bihar Research Soc., vol. 4 : pts. i & iv, Jan. Dec. 1969, 102-114.
- 45 ] Sikdar, J. C., The Jaina Concept of Time, Res. Jour. of Phil., Ranchi, vol. 4.1 (1972), 75-88.
- 46 ] Sikdar, J. C., Eclipses of the Sun and the Moon according to Jaina Astronomy, I. J. H. S., vol. 12, no. 2, Nov. 1977, 127-136.
- 47 ] Singh, A. N., History of Mathematics in India from Jaina Sources. The Jaina Antiquary, 16, no. ii (1950) 54-69, Arrah.
- 48 ] Thibaut, G., On the Sūryaprajñapti, Jour. of the Asiatic Society of Bengal, 49 (1), 1880, 107-127, 181-206.
- 49 ] Thibout, G., Contributions to the Explanations of Jyotisha Vedāṅga, Jour. A. S. of Bengal, 46 (1), 1877, 411-437.
- 50 ] Chakravarty, G. N., Concept of the Structure of Space Time, I. J. H. S., vol. 5, no. 2, Nov. 1970, 219-228.

## (C) BIBLIOGRAPHY OF BOOKS

- 1 ] 'Nature of the Universe', trans. R. E. Latham, Penguin Books, 1951.
- 2 ] 'The Almagest', trans. R. C. Taliaferro, "Great Books of the Western World", series, vol. 16, Book I—Chicago, 1952.
- 3 ] 'De Revolutionibus Orbium Celestium (1543)', Royal Astronomical Society.
- 4 ] 'Dialogue concerning the two chief world systems Ptolemaic and Copernican', trans. Stillman Drake, Univ. of California Press, 1933.
- 5 ] 'Philosophiae Naturalis Principia Mathematica', Drake, A. M., trans. F. Cajori, Univ. of California Press, 1946.
- 6 ] 'Mein Welt bild', Einstein, A., Amsterdam, 1934.
- 7 ] 'The Expanding Universe,' Eddington, A. S., Cambridge, 1933.
- 8 ] 'The Nature of the Universe', Hoyle, F., New York, 1960.
- 9 ] 'A History of Geometrical Methods', Coolidge, J. L., Oxford, 1940.
- 10 ] 'Ideas and Opinions', Einstein, A., London 1956.
- 11 ] 'Cosmology, Old and New', Jain, G. R., Indore, 1942.
- 12 ] 'Spherical Astronomy', Prasad, G., Allahabad, 1973.
- 13 ] 'Bhārattya Jyotiṣa' of Shankara Balkrishṇa Dixit, trans. Jharkhandi, S. N., Lucknow, 1975.
- 14 ] 'Bhārattya Jyotiṣa', Shastri, N. C., New Delhi, 1976.
- 15 ] 'A Concise History of Science in India', Bose, D. M., Sen, S. N., Subbarayappa, B. V., New Delhi, 1971.
- 16 ] 'L' Inde Classique, École Fran, caise- d 'Extrême-Orient', Renou, L. and Filliozat, J., Hanoi, 1953.
- 17 ] 'Bhārtiya Saṃskṛti meṃ Jaina Dharma kā Yogadāna', Bhopal, 1962.

- 18 ] 'The Jaina Sources of the History of Ancient India, (100 B. C. to A. D. 900)', Jain, J. P., Delhi, 1964.
- 19 ] 'Der Jainismus', Von Glassnapp, Berlin, 1925.
- 20 ] 'Viśva Prāhelikā', Muni Mahendra Kumar, II, Bombay, 1969.
- 21 ] 'On Mathematics and Mathematicians', Moritz, R. E., Newyork, 1942 (Dover).
- 22 ] 'Reality-Sarvārtha Siddhi of Pūjyapāda', Jain, S. A., Calcutta, 1960.
- 23 ] 'Jyotiṣasāra', trans. Jain, B. D., Calcutta, 1923.
- 24 ] 'Science and Civilization in China', Needham, J. and Ling, W., vol. 1 (1954), vol. 3 (1959), Cambridge.
- 25 ] 'Ancient Hindu Astronomy', Somayaji, D. A., Dharvar, 1971,
- 26 ] 'The Exact Sciences in Antiquity', Neugebauer, O., Providence, 1957.
- 27 ] 'Census of the Exact Sciences in Sanskrit', Series A, vol. I (1970), vol. II (1971), Philadelphia.
- 28 ] 'History of Philosophy; Eastern and Western', Ed. Radhakrishnan, S, et al., London, 1957. [ This contains an article, 'Scientific Thought in Ancient India' by Singh, A. N., on *Mathematics* and *Astronomy*, pp. 444 et seq. ]
- 29 ] 'The Vedic Cycle of Eclipses', Sharma Shastry, R., Mysore, 1938.
- 30 ] 'Geometry in Ancient and Medieval India', Saraswati, T. A. Delhi, 1978.
- 31 ] 'Treasures of Jaina Bhandaras', Shah, U. P., Ahmedabad, 1978.
- 32 ] 'Science Awakening', Waerden, B. L., Holland, 1945.
- 33 ] 'Āryabhaṭa', Volodarski, A. E., (Russian), Moscow, 1977.
- 34 ] 'History of Mathematics' I; Ribnikov, K. A., (Russian); Moscow, 1960.
- 35 ] 'Albirūni's India', Albiruni, trans. (Hindi), Sharma, R. K., Allahabad, 1967. Cf. also, Sachau, New Delhi, 1964.
- 36 ] 'The Positive Sciences of the Hindus', Seal, B. N., Delhi, 1958.
- 37 ] 'A History of the Kerala School of Hindu Astronomy,' Sarma, K. V., Hoshiarpur, 1972.
- 38 ] 'Hindu Achievement in Exact Sciences', Sarkar, B. K., London, 1918.

- 39 ] 'A History of Science', Sarton, G., vols. I, II, New York, 1965.
- 40 ] 'Āryabhaṭa—Indian Astronomer and Mathematician', Shukla, K. S., New-Delhi, 1976 (INSA).
- 41 ] 'Hindu Astronomy', Brennand, W., London, 1896.
- 42 ] 'Man and the Cosmos' by Ritchie Calder, Britannica Perspectives, vol. 1, 1768–1968, Chicago, 1968.
- 43 ] 'A History of Ancient Mathematical Astronomy', Neugebauer, O., Berlin, 1975.
- 44 ] 'Kevala Jñāna Praśna Cūḍāmaṇi' ed. Shastri, N. C., Kashi.
- 45 ] 'Theories of the Universe', Munitz, M. K., Illinois, 1957.
- 46 ] 'Die Kosmographie der Inder,' Kirfel, W., Bonn, 1920.
-

## (D) ABBREVIATION

1. C. P. Candraprajñāpti
2. D. Dhavalā ( commentary )
3. G. A. Gaṇitānuyoga
4. G. J. K. Gommaṭasāra Jivakāṇḍa
5. L. P. Loka prakāśa
6. L. V. Loka vibhāga
7. P. A. Pañcāstikāya
8. R. S. P. Ratna Sañcaya Prakaraṇa
9. S. K. Śaṭ khaṇḍāgama
10. S. P. Sūryaprajñāpti
11. T. P. Tiloyapaṇṇatti
12. T. P. G. Tiloyapaṇṇatti kā Gaṇita
13. T. S. Trilokasāra
14. V. P. Viśvaprahelikā.

— — — — —

APPENDIX - A

REST IS EMPTY SPACE  
OR NON-UNIVERSE

THE UNIVERSE

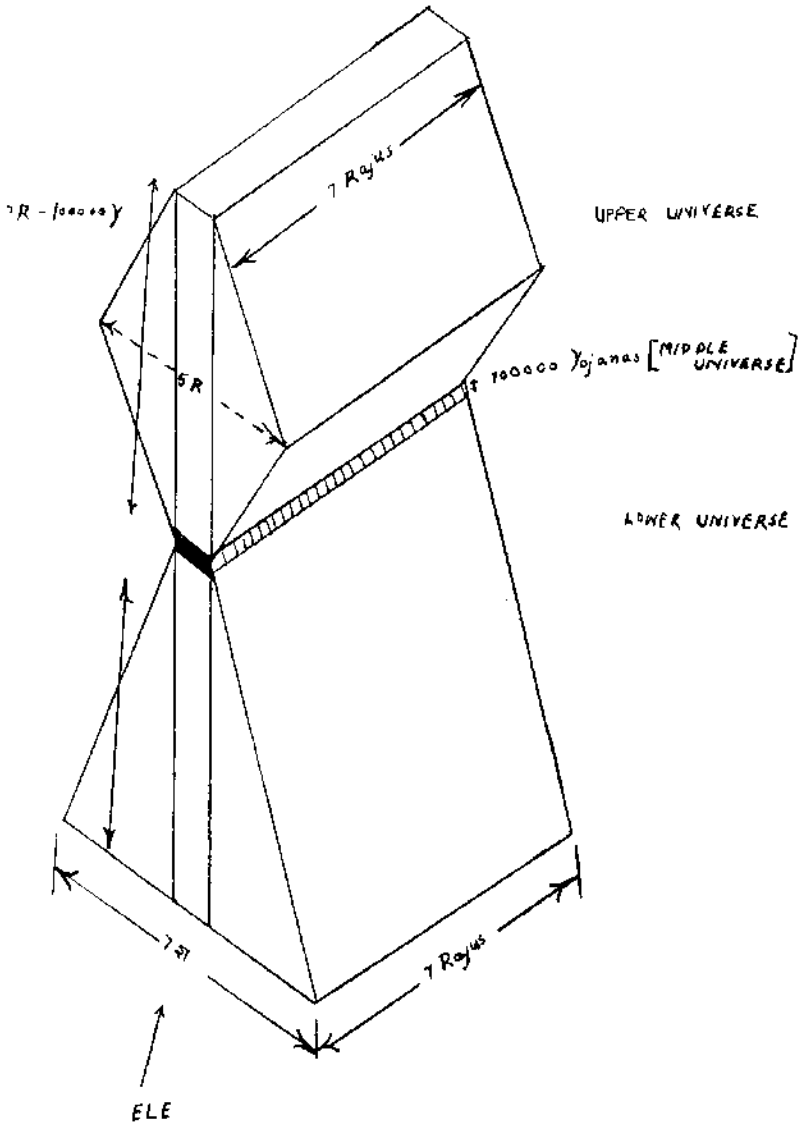

THE UNIVERSE IS CONSTITUTED OF SIX  
TYPES OF FLUENTS: BIOS, MATTER,  
SPACE, TIME, AETHER and ANTI-ABNER  
(JĪVA, PUDGALA, ĀKĀŚA; KĀLA,  
DHARMA and ADHARMA)

APPENDIX - B  
THE UNIVERSE

